

## Chip Common Mode Choke-CMH Series

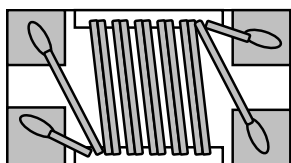

### Features

- Small Chip Inductor with Ferrite Core and Two Line Types Wire wound.
- Highly Effective in Noise Suppression. High Common-mode Impedance at Noise Band and Low Differential-Mode Impedance at Signal Band.
- Low Differential-Mode Impedance with High Coupling Factor, There is Almost No Distortion on High Speed Signal.
- Operating temperature -40°C~85°C.

### Construction

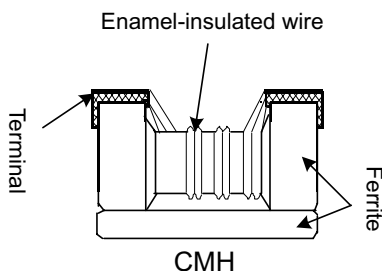
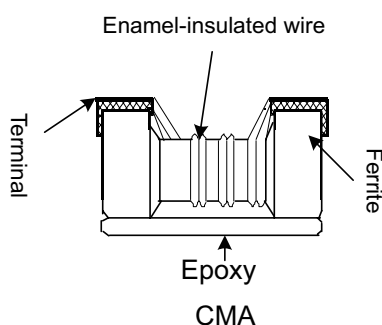

### Applications

- EMI Radiation Noise Suppression for Any Electronic Device.
- USB Line for Personal Computers and Peripheral.
- IEEE 1394 Line for Personal Computers ,DVC,STB.
- LCD Panels. Low-Voltage Differential Signal (LVDS),

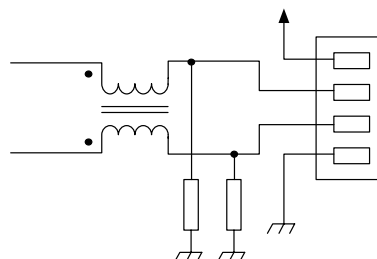
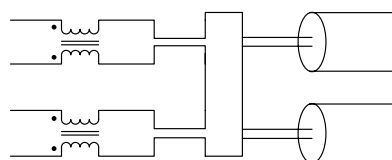

### Part Numbering

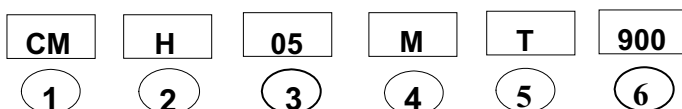

#### ① Product Type

Product Type	
CM	SMD Common Mode Choke

#### ② Shielding Type

Codes	Type
A	Non Shielding
H	Shielding

#### ③ Dimensions (LxW)

Codes	Dimensions (LxW)	EIA
05	2.10×1.20mm	0805
06	3.20×1.60mm	1206

#### ④ Impedance Tolerance

Codes	Resistance Tolerance
M	±20%

#### ⑤ Packaging

Codes	Type
T	Taping Reel
B	Bulk

#### ⑥ Impedance

Codes	Type
900	90Ω
121	120Ω
102	1000Ω
222	2200Ω



**Dimensions**

Unit: mm

TYPE	A	B	C	E	F	G	H	I	J	K
CMA05	2.1±0.2	1.2±0.2	1.0±0.2	0.45	1.2	0.4	0.8	0.4	0.4	0.90
CMH05	2.0±0.2	1.2±0.2	1.2±0.2	0.45	1.2	0.4	0.8	0.4	0.4	0.90
CMH06	3.2±0.2	1.6±0.2	1.8±0.2	0.60	2.0	0.6	1.6	0.6	0.4	1.05

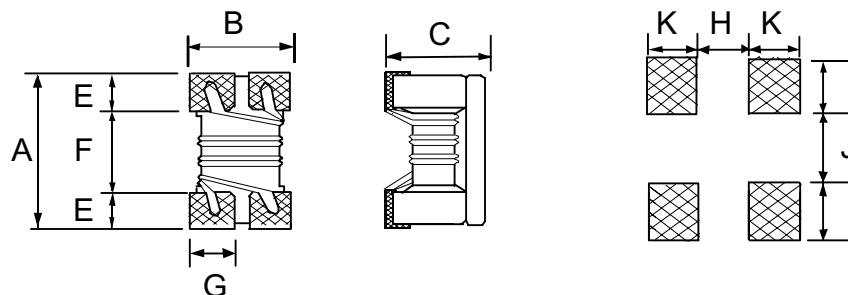

**Standard Electrical Specifications**

Part Number	Impedance(Ω) @100MHZ	Resistance Rdc(Ω) Max.	Rated Current Idc(mA) Max.	Rated Voltage Vdc(V)	Withstanding Voltage Vdc (V)	Insulation Resistance (MΩ) Min.
CMA05MT670	67	0.35	330	50	125	10
CMA05MT900	90	0.35	330	50	125	10
CMA05MT121	120	0.45	280	50	125	10
CMA05MT181	180	0.50	250	50	125	10

CMH05MT670	67	0.25	400	50	125	10
CMH05MT900	90	0.35	330	50	125	10
CMH05MT121	120	0.30	370	50	125	10
CMH05MT181	180	0.35	330	50	125	10
CMH05MT201	200	0.35	330	50	125	10
CMH05MT261	260	0.40	300	50	125	10
CMH05MT371	370	0.40	280	50	125	10

CMH06MT900	90	0.30	370	50	125	10
CMH06MT161	160	0.40	340	50	125	10
CMH06MT261	260	0.50	310	50	125	10
CMH06MT601	600	0.80	260	50	125	10
CMH06MT102	1000	1.00	230	50	125	10
CMH06MT222	2200	1.20	200	50	125	10

All specifications are subject to change without notice.



**Characteristics (Impedance vs. Frequency)-CMA05**

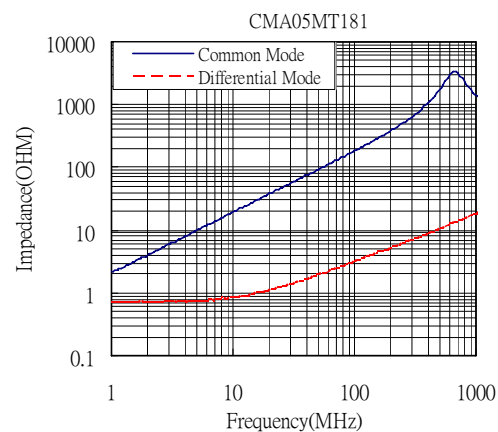
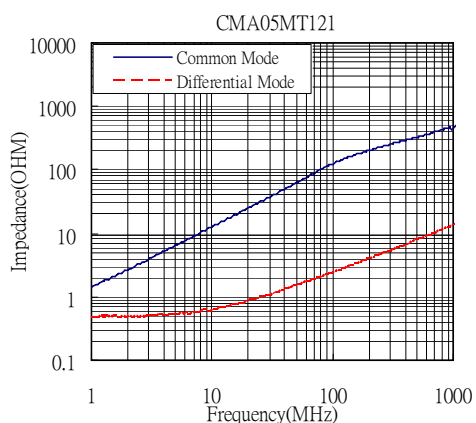
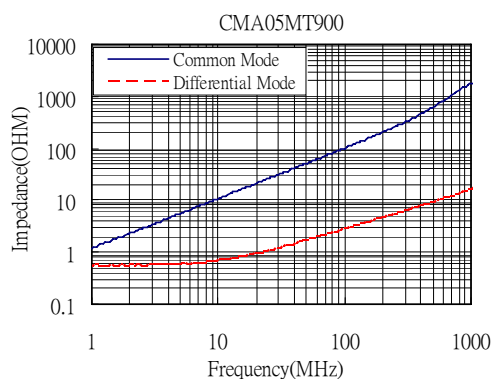
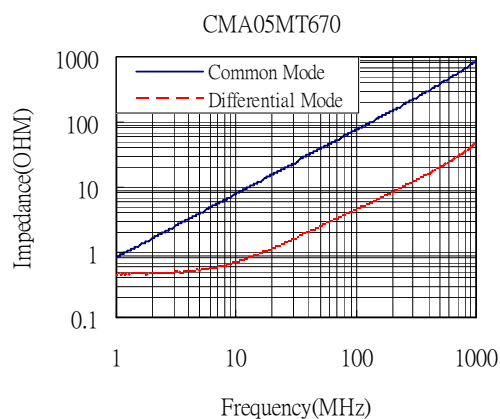

**Characteristics (Impedance vs. Frequency)-CMH05**

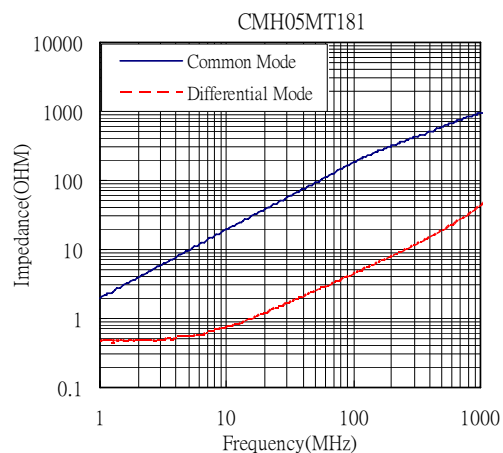
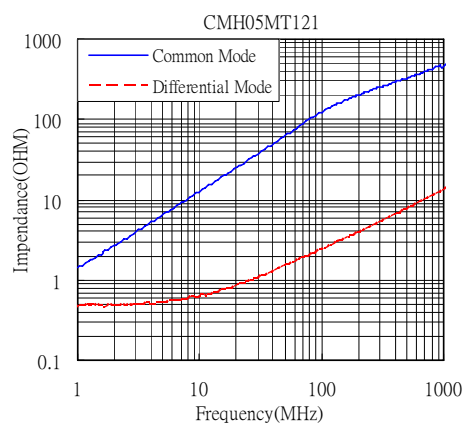
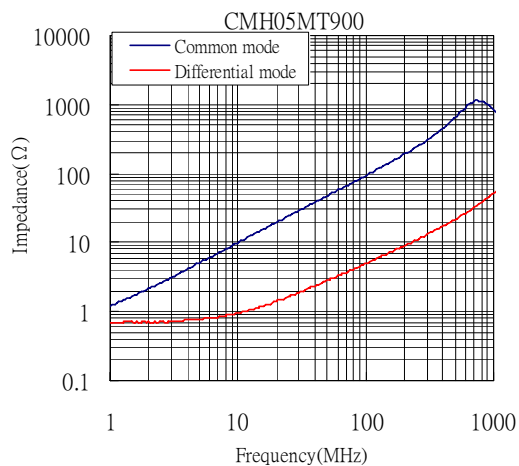
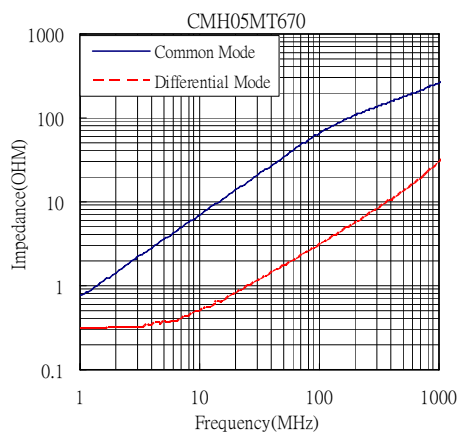

**Characteristics (Impedance vs. Frequency)-CMH05**

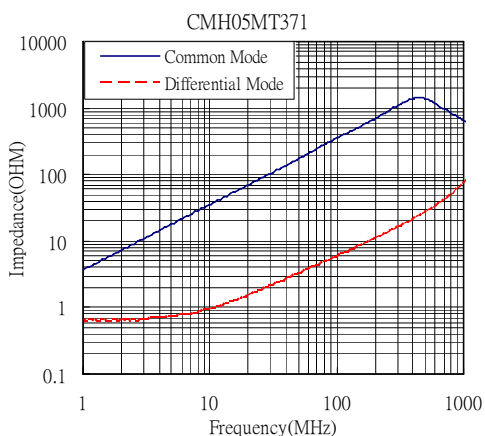
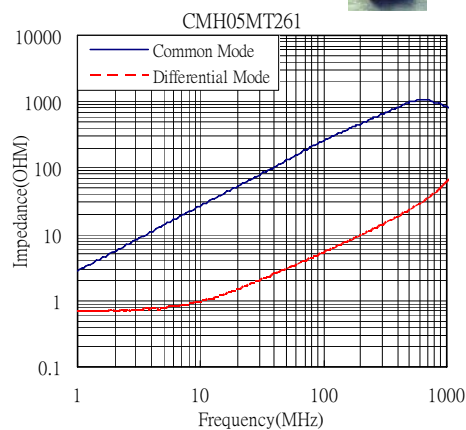
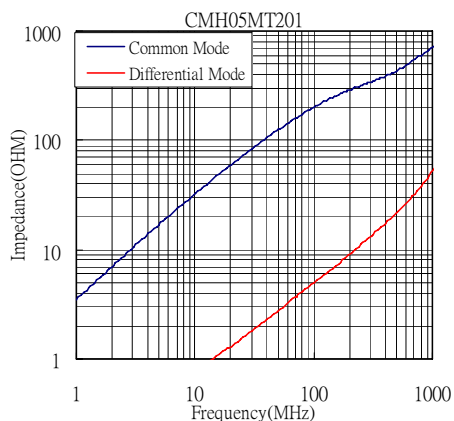

**Characteristics (Impedance vs. Frequency)-CMH06**

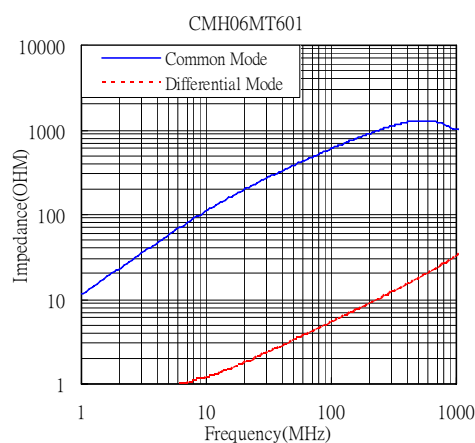
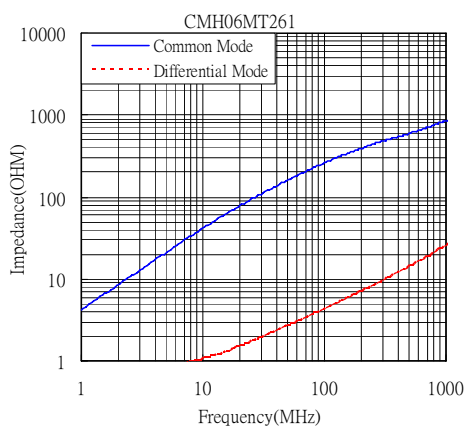
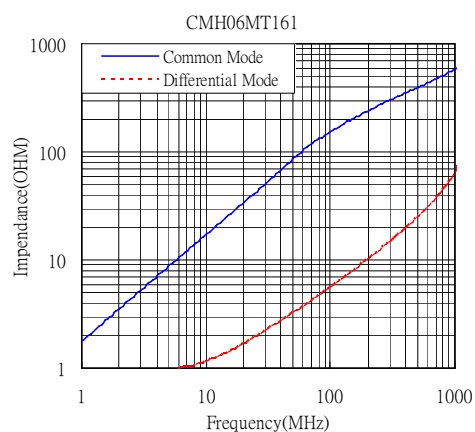
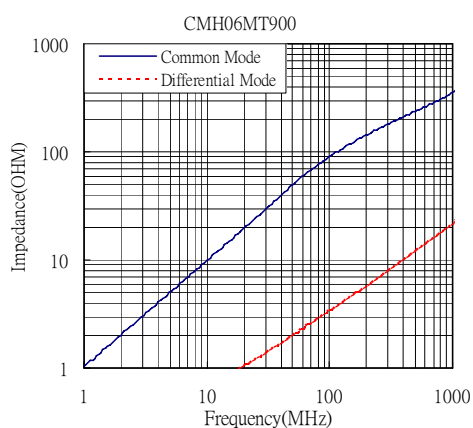

### Characteristics (Impedance vs. Frequency)-CMH06

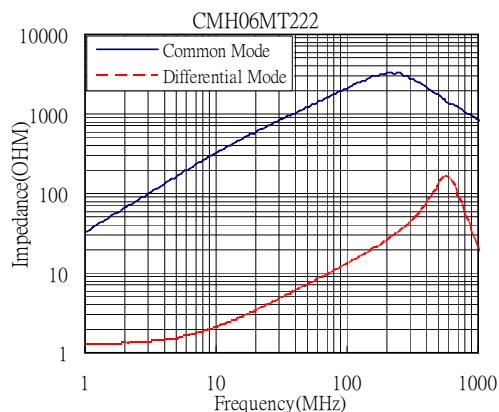
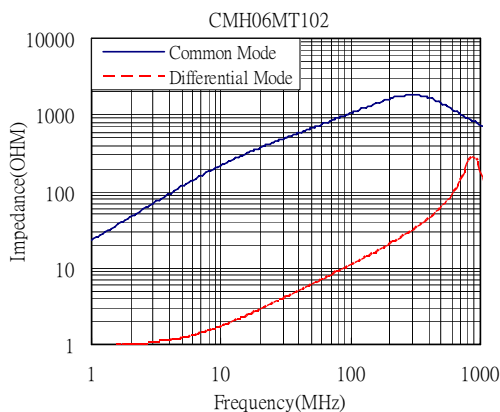

### Packaging

#### Packaging Quantity

Unit: PCS

Series	Packaging	Emboss Plastic Tape
CMA05		2000
CMH05		2000
CMH06		2000

#### Reel Specifications

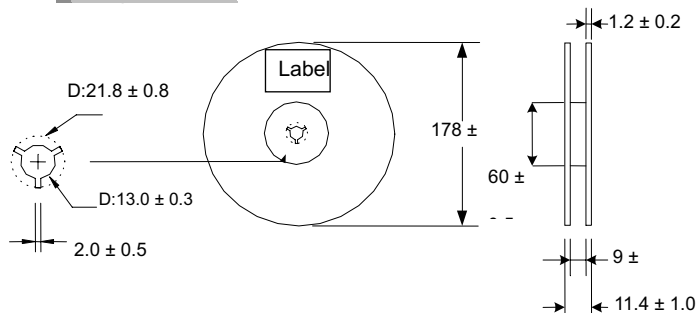

#### Emboss Plastic Tape Specifications

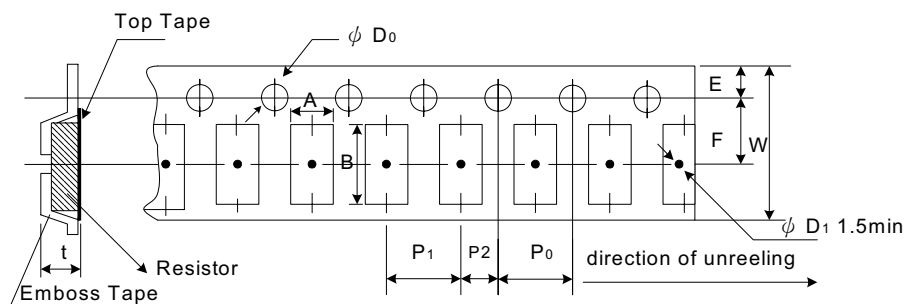

Unit: mm

Codes	A	B	W	E	F	P <sub>0</sub>	P <sub>1</sub>	P <sub>2</sub>	ψD <sub>0</sub>	t
CMA05	1.40±0.10	2.55±0.05	8.0±0.20	1.75±0.10	3.5±0.10	4.00±0.10	4.00±0.10	2.00±0.10	1.50+0.10	1.35±0.10
CMH05	1.40±0.10	2.55±0.05	8.0±0.20	1.75±0.10	3.5±0.10	4.00±0.10	4.00±0.10	2.00±0.10	1.50+0.10	1.35±0.10
CMH06	1.90±0.10	3.50±0.05	8.0±0.20	1.75±0.10	3.5±0.10	4.00±0.10	4.00±0.10	2.00±0.10	1.50+0.10	2.10±0.10

#### Leader / Tape

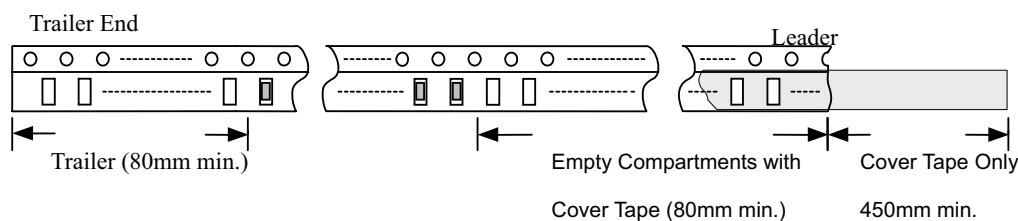

#### Peel-off Force

The force for tearing off cover tape is 0.05~0.69(N) in the arrow direction at

the following conditions:

Temperature : 5 ~ 35°C

Humidity : 45 ~ 85%

Atmospheric pressure : 860 ~ 1060 hpa

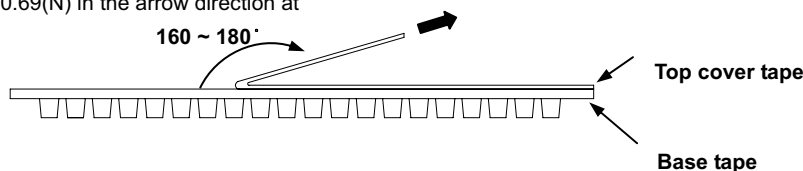



## Environmental Characteristics

### Electrical Performance Test

Test Items	Specifications	Test Conditions / Test Methods
Impedance	Refer to standard electrical characteristic spec.	LCR Meter HP 4291B
DC Resistance RDC		Micro-Ohm meter (GOM-801G)
Withstand Voltage (VDC)	Component should not be damaged	Test Voltage : 2.5 Times Rated Voltage Testing Time : 60 sec. Charge Current : 0.5mA
Rated Voltage (VDC)		Test Voltage : Rated Voltage Testing Time : 1 to 5 sec. Charge Current : 1mA
Insulation Resistance (I.R)		Charge Current : 1minute
		10M ohm min

### Mechanical Performance Test

Test Items	Specifications	Test Conditions / Test Methods
Component Adhesion (push Test)	Base: 0805 $\geq 2$ Lbs Cover: 0805 $\geq 1$ Lbs Base: 1206 $\geq 4$ Lbs Cover: 1206 $\geq 2$ Lbs	The component should be soldered ( $232^{\circ}\text{C} \pm 5^{\circ}\text{C}$ for 10 sec.) to tinned copper substrate. Applied force gauge to the side of component It must withstand force of 2 or 4 pounds without failure of the component.
Drop Test	Component should not be damaged	Dropping chip by each side and corner. Drop 10 times in total Drop height :100cm Drop weight:125g
Solderability Test	The terminal should at least be 90% covered with solder	The component shall be dipped in a melted solder bath At $235 \pm 5^{\circ}\text{C}$ for 5 seconds.
Vibration Test (Low Frequency)	Component should not be damaged	1. Amplitude: 1.5 m/m 2. Frequency: 10-55-10 Hz(1min) 3. Direction: X, Y, Z 4. Duration: 2 Hrs/X, Y, Z

### Climatic Test

Test Items	Specifications	Test Conditions / Test Methods
Low Temperature Storage Test	Impedance change : Within $\pm 20\%$ Without distinct damage in appearance.	1. Temp: $-40 \pm 2^{\circ}\text{C}$ 2. Time: $1000 \pm 48$ Hours 3. Component should be tested after 1hour at room temperature.
Thermal Shock Test		<p>Total : 5 Cycles</p>
High Temperature Storage Test		1. Temp : $85 \pm 2^{\circ}\text{C}$ 2. Time : $1000 \pm 48$ Hours 3. Component should be tested after 1hour at room temperature.
Humidity Test		1. Temp : $40 \pm 2^{\circ}\text{C}$ 2. R.H. : 90 – 95% 3. Time : $48 \pm 2$ Hours
High Temperature Load Life Test	There should be no evidence of short or open circuit	1. Temp : $85 \pm 2^{\circ}\text{C}$ 2. Time : $96 \pm 12$ Hours 3. Load : Allowed DC Current
Low Temperature Load Life Test		1. Temp : $-40 \pm 2^{\circ}\text{C}$ 2. Time : $96 \pm 12$ Hours 3. Load : Allowed DC Current

※Storage Temperature : $25 \pm 3^{\circ}\text{C}$ ; Humidity:<80%RH