

Thin Film Chip Inductor – AL Series



Features

- A Photo Lithographic Single Layer Ceramic Chip
- High SRF, Excellent Q, Superior Temperature Stability
- Tight Tolerance of $\pm 1\%$ or $\pm 0.1\text{nH}$
- Self Resonant Frequency Controlled within 10%
- Stable Inductance in High Frequency Circuit
- Highly Stable Design for Critical Needs

Applications

- Cellular Telephone, Pagers and GPS Products
- VCO, TCXO Circuit and RF Transceiver Module
- Wireless LAN, Bluetooth Module, Communication Appliances

Construction

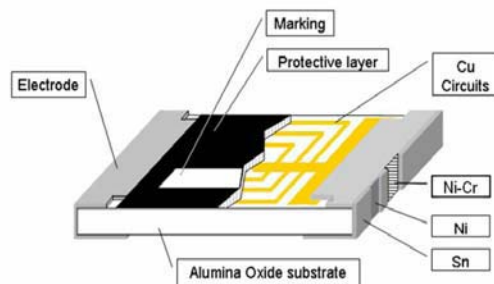
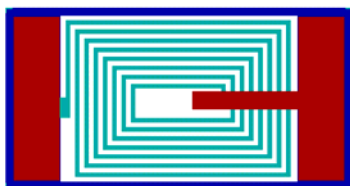

Part Numbering

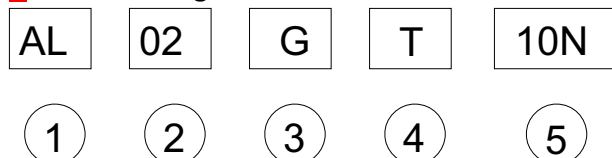

① Product Type

Product Type	
AL	Thin Film Chip Inductor

② Dimensions (L×W)

Codes	Dimensions (L×W)	EIA
AL03	1.6×0.8mm	0603
AL02	1.0×0.5mm	0402

③ Inductance Tolerance

Codes	Type
J	$\pm 5\%$
H	$\pm 3\%$
G	$\pm 2\%$
F	$\pm 1\%$
S	$\pm 0.3\text{nH}$
C	$\pm 0.2\text{nH}$
B	$\pm 0.1\text{nH}$

④ Packaging

Codes	Type
T	Taping Reel

⑤ Inductance

Codes	Type
1N0	1.0nH
10N	10nH
20N8	20.8nH
R10	100nH

Standard Electrical Specifications

0402 Chip Inductors

Inductance (nH)	Inductance Tolerance (% or nH)	Quality Factor /min.	Resistance DC/Max (Ohm)	Current DC/Max (mA)	Self Resonant Frequency/min. (GHz)
0.2	0.1/0.2/0.3nH	13 / 500MHz	0.10	800	14
0.4	0.1/0.2/0.3nH	13 / 500MHz	0.10	800	14
0.8	0.1/0.2/0.3nH	13 / 500MHz	0.15	700	14
1.0	0.1/0.2/0.3nH	13 / 500MHz	0.15	700	12
1.2	0.1/0.2/0.3nH	13 / 500MHz	0.15	700	12
1.5	0.1/0.2/0.3nH	13 / 500MHz	0.25	700	10
1.6	0.1/0.2/0.3nH	13 / 500MHz	0.25	560	10
1.8	0.1/0.2/0.3nH	13 / 500MHz	0.25	560	10
2.0	0.1/0.2/0.3nH	13 / 500MHz	0.35	560	8
2.2	0.1/0.2/0.3nH	13 / 500MHz	0.35	440	8
2.7	0.1/0.2/0.3nH	13 / 500MHz	0.35	440	8
3.1	0.1/0.2/0.3nH	13 / 500MHz	0.45	380	6
3.3	0.1/0.2/0.3nH	13 / 500MHz	0.45	380	6
3.6	0.1/0.2/0.3nH	13 / 500MHz	0.55	380	6
3.9	0.1/0.2/0.3nH	13 / 500MHz	0.55	340	6
4.7	0.1/0.2/0.3nH	13 / 500MHz	0.65	320	6
5.6	0.1/0.2/0.3nH	13 / 500MHz	0.85	280	6
5.9	0.1/0.2/0.3nH	13 / 500MHz	0.85	280	6
6.8	0.1/0.2/0.3nH	13 / 500MHz	1.05	260	6
7.2	0.1/0.2/0.3nH	13 / 500MHz	1.05	260	6
8.0	0.1/0.2/0.3nH	13 / 500MHz	1.25	220	5.5
8.2	0.1/0.2/0.3nH	13 / 500MHz	1.25	220	5.5
9.1	0.1/0.2/0.3nH	13 / 500MHz	1.25	220	5.5
10	1/2/3/5%	13 / 500MHz	1.35	200	4.5
12	1/2/3/5%	13 / 500MHz	1.55	180	3.7
13.8	1/2/3/5%	13 / 500MHz	1.75	180	3.7
15	1/2/3/5%	13 / 500MHz	1.75	130	3.3
17	1/2/3/5%	13 / 500MHz	1.95	100	3.1
18	1/2/3/5%	13 / 500MHz	2.15	100	3.1
20.8	1/2/3/5%	13 / 500MHz	2.55	90	2.8
22	1/2/3/5%	13 / 500MHz	2.65	90	2.8
27	1/2/3/5%	13 / 500MHz	3.25	75	2.5
33	/5%	13 / 500MHz	3.75	75	2.5

Test Equipment: HP4286A+Agilent 16196B

* Viking is capable of manufacturing the optional spec based on customer's requirement.

Inductor Electrical Characteristics-0402 Series

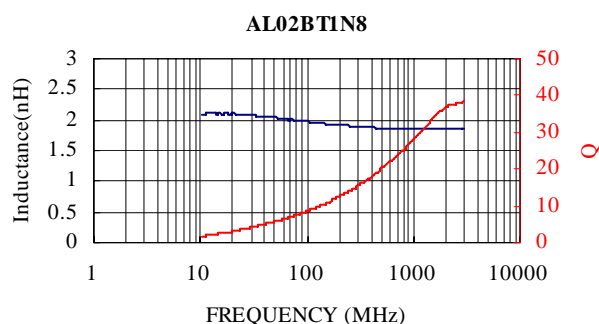
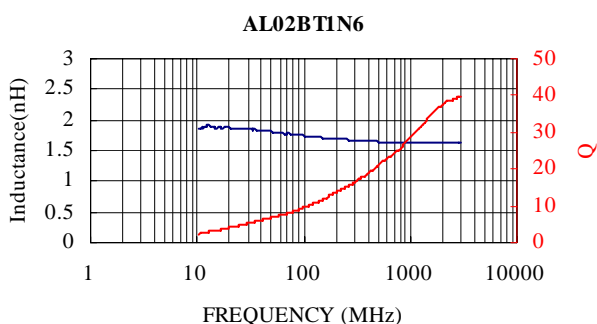
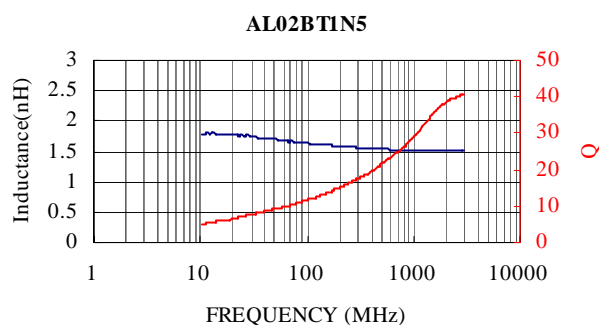
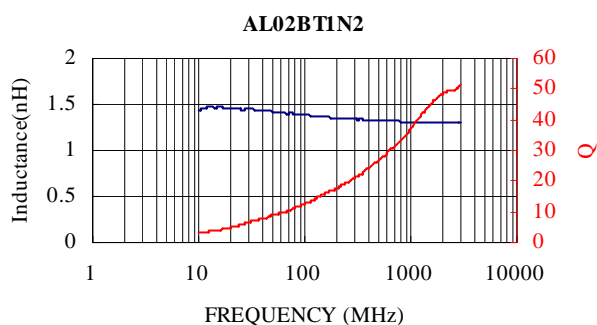
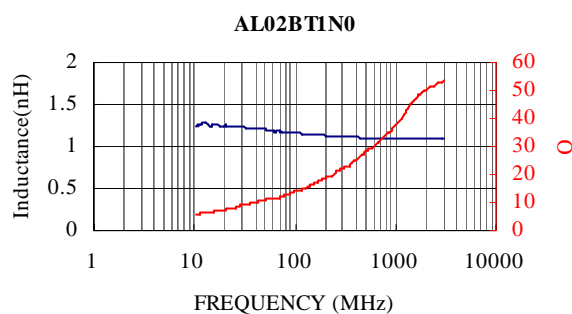
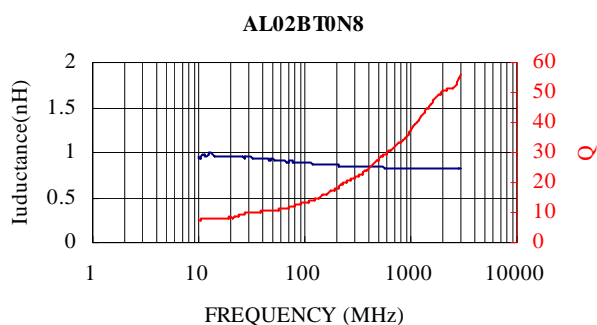
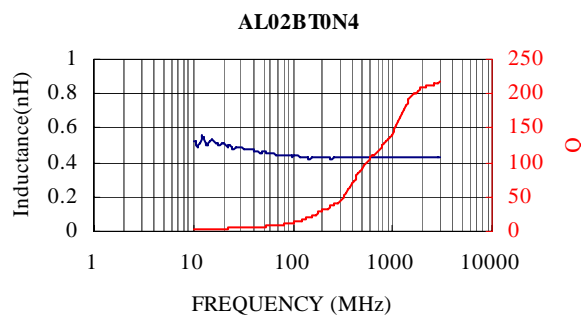
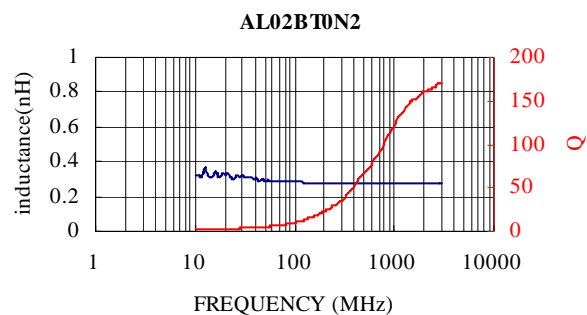

Inductor Electrical Characteristics-0402 Series

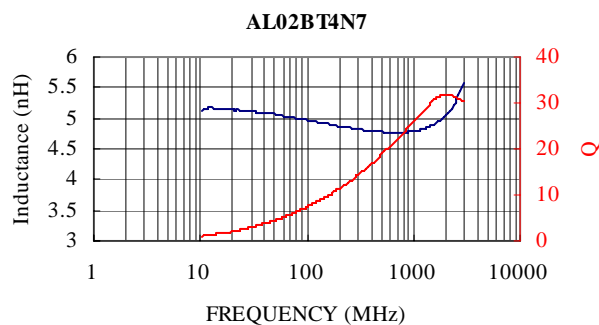
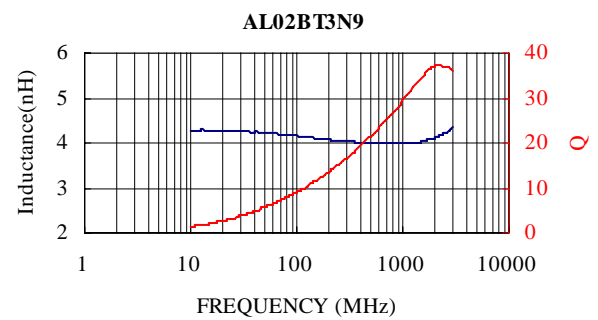
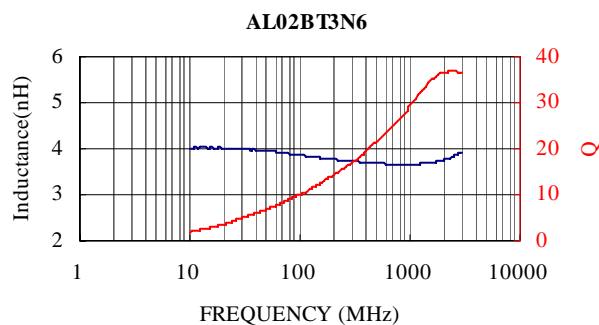
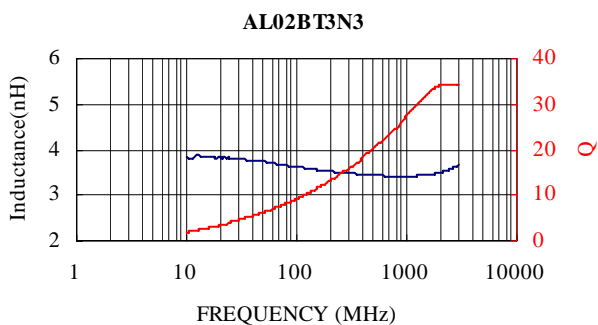
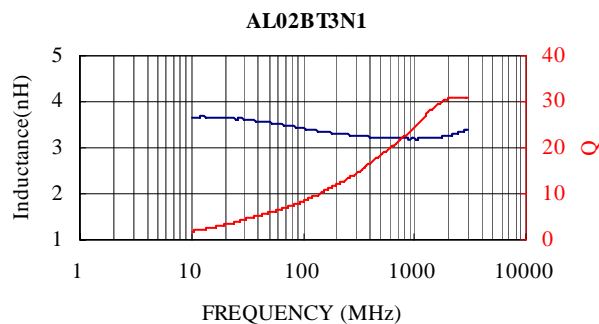
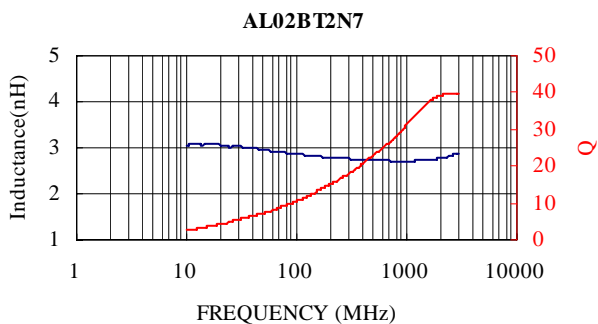
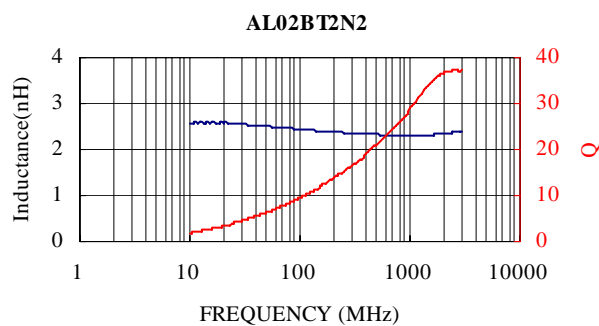
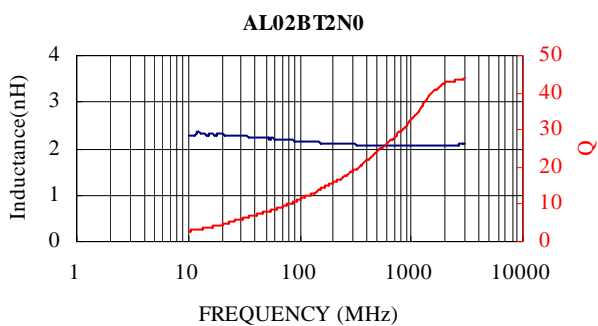

Inductor Electrical Characteristics-0402 Series

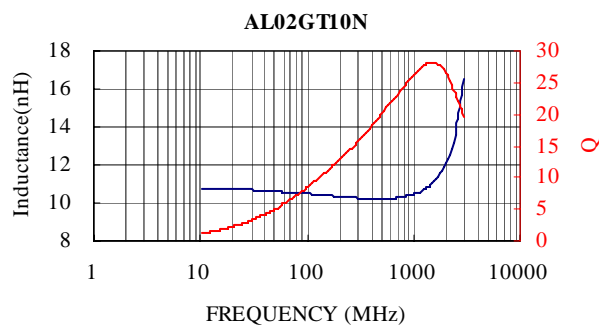
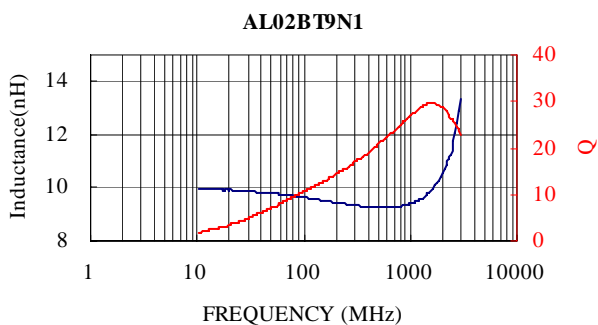
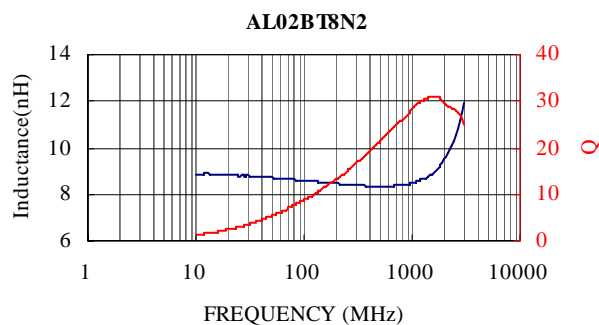
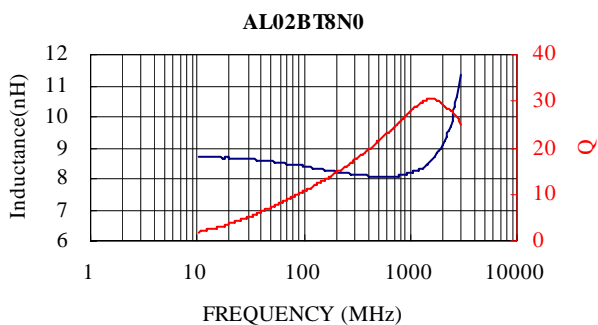
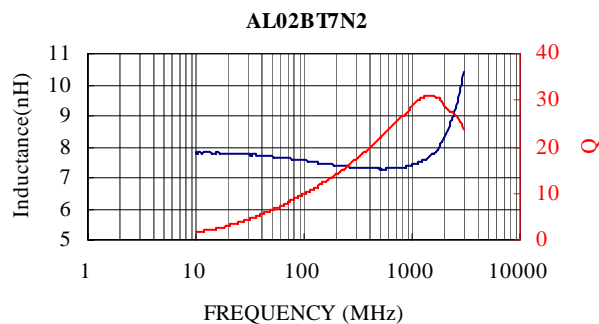
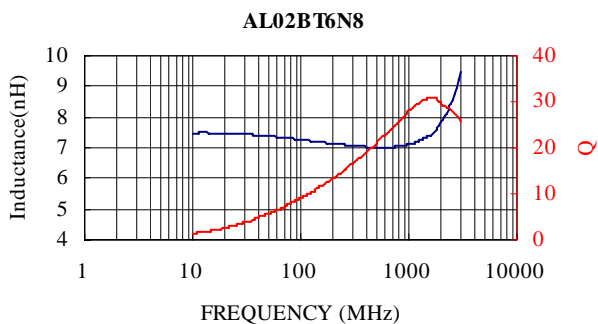
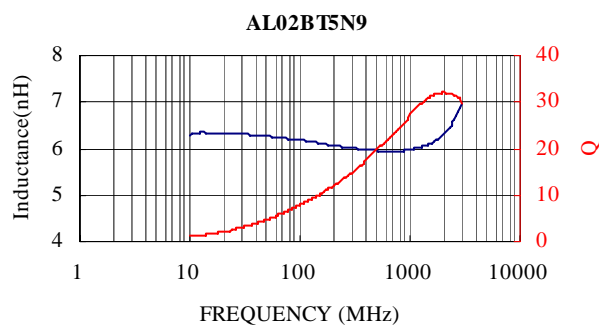
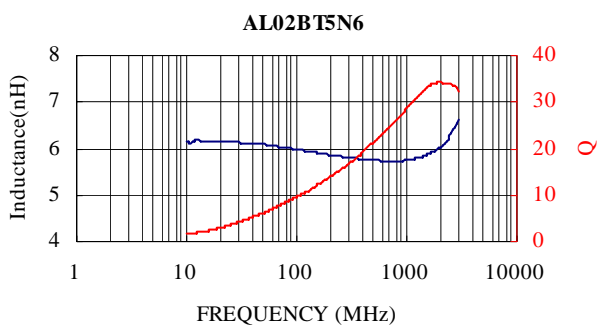

Inductor Electrical Characteristics-0402 Series

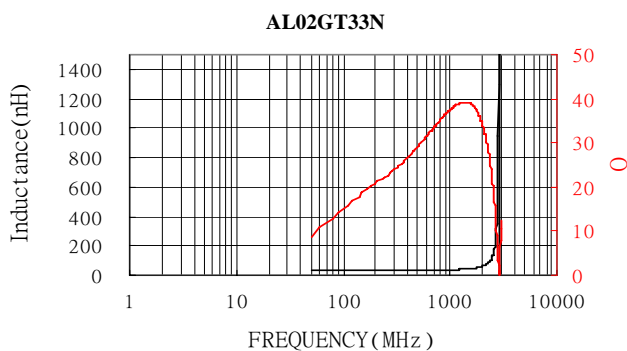
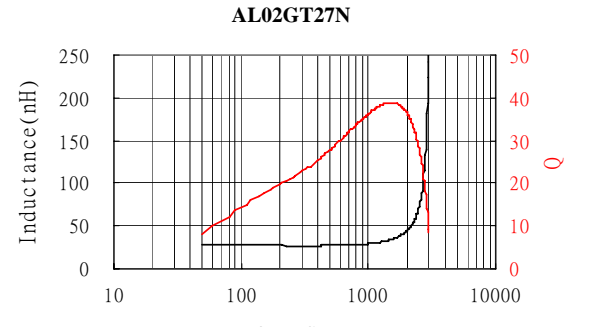
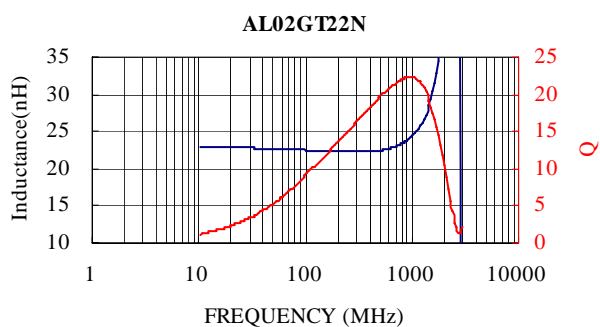
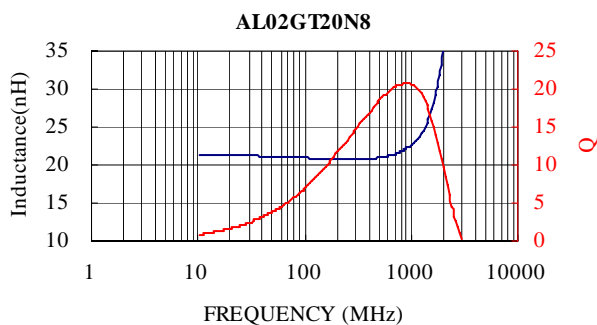
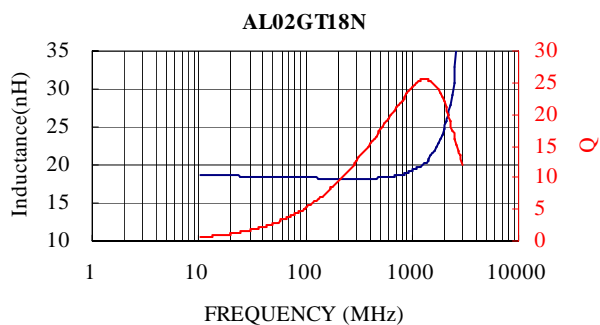
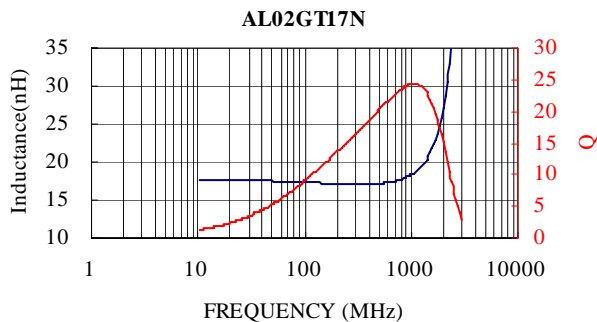
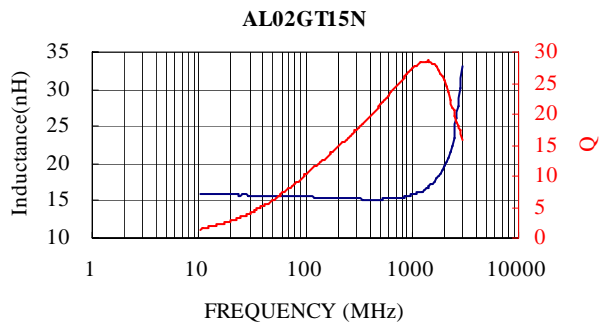
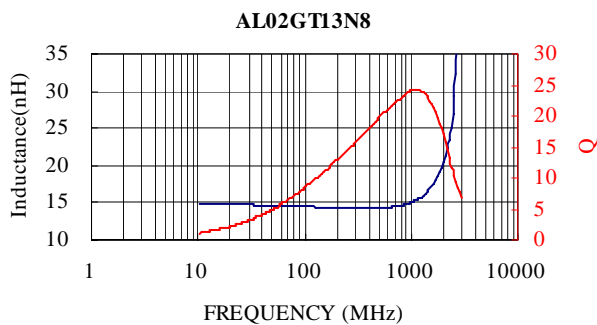
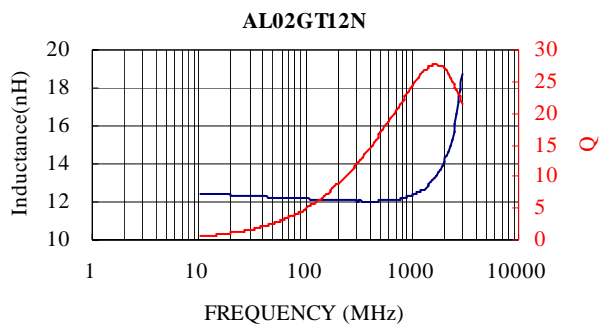

Packaging

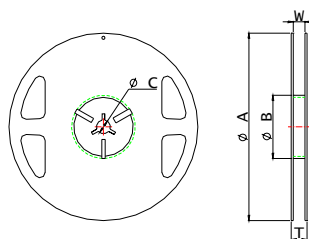

Reel Specifications & Packaging Quantity

Unit: mm

Codes	ΦA	ΦB	ΦC	W	T	Paper Tape (EA)
AL02	178±1	60.2±0.5	13.0±0.50	13.2±1.50	16.0±0.20	10,000
AL03	178±1	60.0±0.5	13.0±0.20	9.00±0.5	12.0±0.15	5,000

Paper Tape Specifications

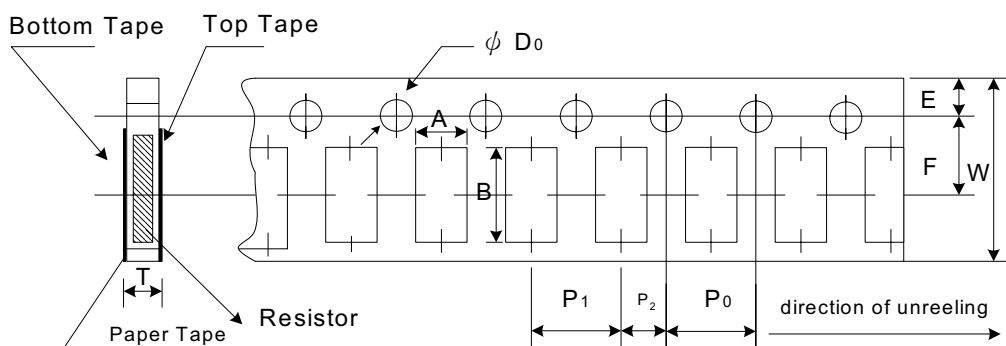

Unit: mm

Codes	A	B	W	E	F	P ₀	P ₁	P ₂	ΦD ₀	T
AL02	0.70±0.05	1.16±0.05	8.00±0.10	1.75±0.05	3.5±0.05	4.00±0.10	2.00±0.05	2.00±0.05	1.55±0.05	0.40±0.03
AL03	1.10±0.05	1.90±0.05	8.00±0.10	1.75±0.05	3.5±0.05	4.00±0.10	4.00±0.10	2.00±0.05	1.55±0.05	0.60±0.03

Environmental Characteristics

Item	Specification	Test Method
1 Bending Test	As SPEC.	JIS-C-5202-6.1.4 Bending Amplitude 3mm for 10 seconds
2 Dielectric Withstand Voltage	>100V	MIL-STD-202F Method 301. Apply 100VA (rms) for 1minute.
3 Insulation Resistance	>1000MΩ	MIL-STD-202F Method 302 Apply 100VDC for 1minute.
4 Resistance to Soldering Heat	ΔL ≤ 10%	MIL-STD-202F Method 210E 260±5°C, 10±1seconds
5 High Temperature Exposure	ΔL ≤ 10%	JIS-C-5202-7.2 85±2°C, 1000 +48/-0 hours
6 Moisture Resistance	ΔL ≤ 10%	MIL-STD-202F Method 103B 40±2°C, 90~95%RH, 1000 +48/-0 hours
7 Low Temperature Storage	ΔL ≤ 10%	JIS-C-5202-7.1 -40±3°C, 1000 +48/-0 hours
8 Temperature Cycle	ΔL ≤ 10%	JIS-C-5202-7.4 -40/RT/85/RT, 10 cycles
9 Solderability	95% min coverage	MIL-STD-202F Method 208H 235°C±5°C, 2±0.5(sec)

* Storage Temperature :25±3°C; Humidity <80%RH