

## Thin Film Chip Inductor – AL Series



### Features

- A Photo Lithographic Single Layer Ceramic Chip
- High SRF, Excellent Q, Superior Temperature Stability
- Tight Tolerance of  $\pm 1\%$  or  $\pm 0.1\text{nH}$
- Self Resonant Frequency Controlled within 10%
- Stable Inductance in High Frequency Circuit
- Highly Stable Design for Critical Needs

### Applications

- Cellular Telephone, Pagers and GPS Products
- VCO, TCXO Circuit and RF Transceiver Module
- Wireless LAN, Bluetooth Module, Communication Appliances

### Construction

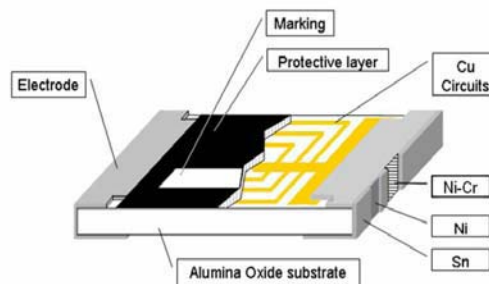
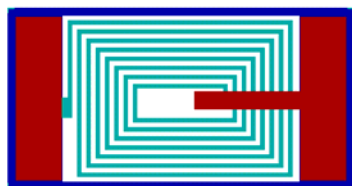

### Part Numbering

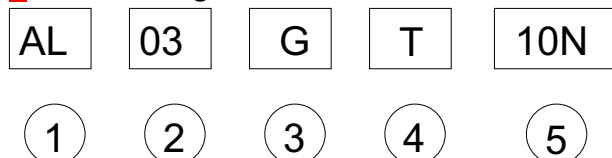

#### ① Product Type

Product Type	
AL	Thin Film Chip Inductor

#### ② Dimensions (L×W)

Codes	Dimensions (L×W)	EIA
AL03	1.6×0.8mm	0603
AL02	1.0×0.5mm	0402

#### ③ Inductance Tolerance

Codes	Type
J	$\pm 5\%$
H	$\pm 3\%$
G	$\pm 2\%$
F	$\pm 1\%$
S	$\pm 0.3\text{nH}$
C	$\pm 0.2\text{nH}$
B	$\pm 0.1\text{nH}$

#### ④ Packaging

Codes	Type
T	Taping Reel

#### ⑤ Inductance

Codes	Type
1N0	1.0nH
10N	10nH
20N8	20.8nH
R10	100nH

## Dimensions

Unit: mm

Codes	A	B	C	D
AL03	1.6±0.10	0.8±0.10	0.45±0.10	0.3±0.20
AL02	1.0±0.05	0.5±0.05	0.32±0.05	0.2±0.10

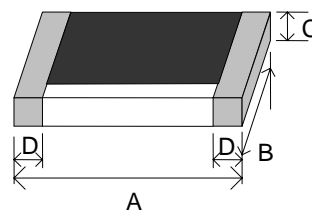

## Standard Electrical Specifications

### 0603 Chip Inductors

Inductance (nH)	Inductance Tolerance (% or nH)	Quality Factor /min.	Resistance DC/Max (Ohm)	Current DC/Max (mA)	Self Resonant Frequency/min. (GHz)
1.0	0.1/0.2/0.3nH	15 / 300MHz	0.35	800	13
1.2	0.1/0.2/0.3nH	15 / 300MHz	0.35	800	13
1.5	0.1/0.2/0.3nH	15 / 300MHz	0.35	800	10
1.8	0.1/0.2/0.3nH	15 / 300MHz	0.35	300	10
2.2	0.1/0.2/0.3nH	15 / 300MHz	0.35	300	8
2.7	0.1/0.2/0.3nH	15 / 300MHz	0.45	300	6
3.3	0.1/0.2/0.3nH	15 / 300MHz	0.45	300	6
3.9	0.1/0.2/0.3nH	15 / 300MHz	0.45	300	6
4.7	0.1/0.2/0.3nH	15 / 300MHz	0.55	300	5
5.6	0.1/0.2/0.3nH	15 / 300MHz	0.65	300	5
6.8	0.1/0.2/0.3nH	15 / 300MHz	0.75	300	5
8.2	0.1/0.2/0.3nH	15 / 300MHz	0.95	300	4
10	1/2/3/5%	15 / 300MHz	0.95	300	4
12	1/2/3/5%	15 / 300MHz	1.05	300	3
15	1/2/3/5%	15 / 300MHz	1.35	300	3
18	1/2/3/5%	15 / 300MHz	1.65	300	2
22	1/2/3/5%	15 / 300MHz	1.95	250	2
27	1/2/3/5%	15 / 300MHz	2.35	250	2
33	1/2/3/5%	15 / 300MHz	2.75	250	1.5
39	1/2/3/5%	15 / 300MHz	3.00	200	1.5
47	1/2/3/5%	15 / 300MHz	3.00	200	1.5
56	1/2/3/5%	15 / 300MHz	5.00	150	1
68	1/2/3/5%	15 / 300MHz	5.00	150	1
100	2/3/5%	15 / 300MHz	7.50	100	1

Test Equipment: HP4286A+Agilent 16196A

**Inductor Electrical Characteristics-0603 Series**

**AL03BT1N0**

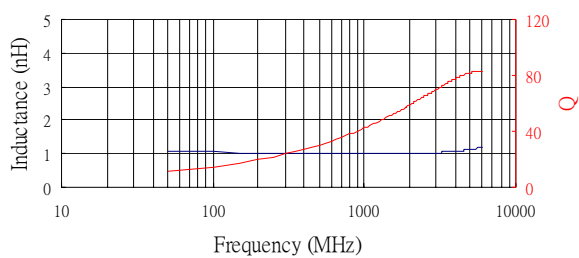

**AL03BT1N2**

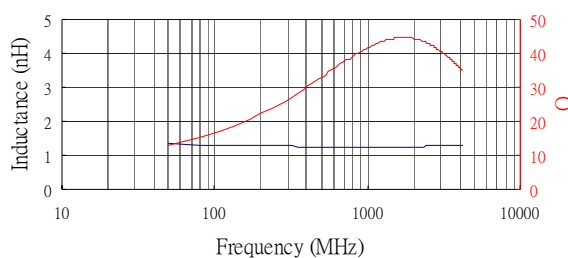

**AL03BT1N5**

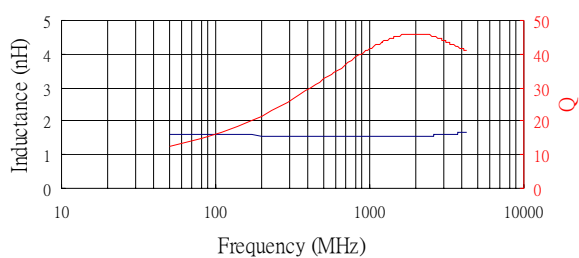

**AL03BT1N8**

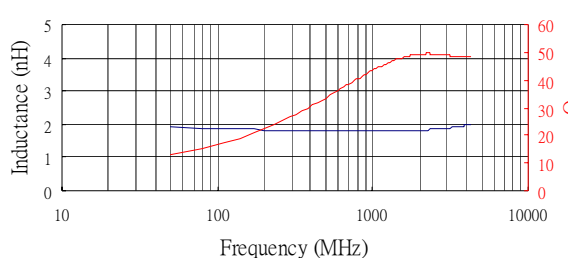

**AL03BT2N2**

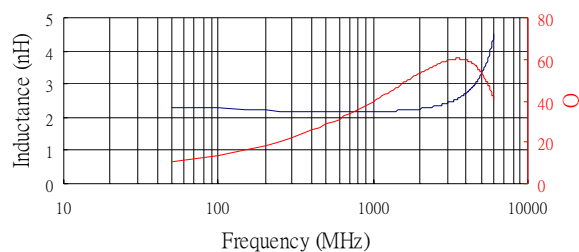

**AL03BT2N7**

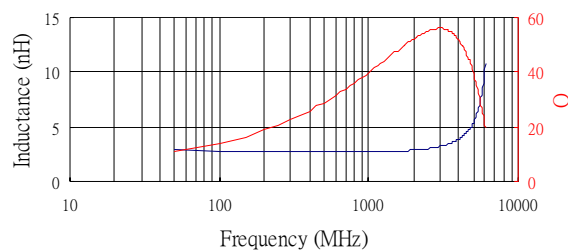

**AL03BT3N3**

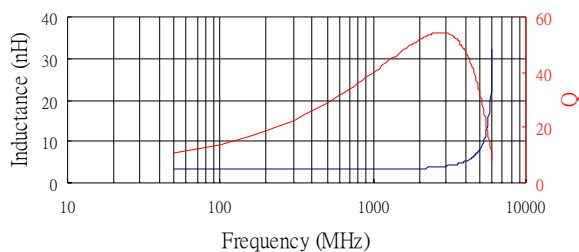

**AL03BT3N9**

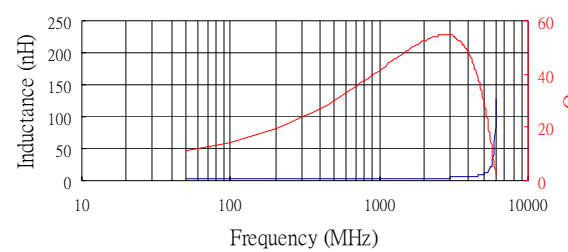

**Inductor Electrical Characteristics-0603 Series**

**AL03BT4N7**

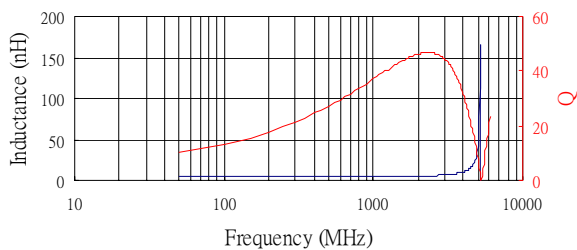

**AL03BT5N6**

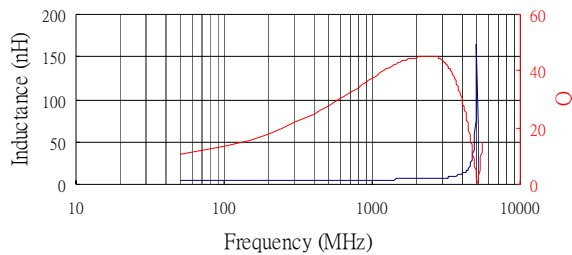

**AL03BT6N8**

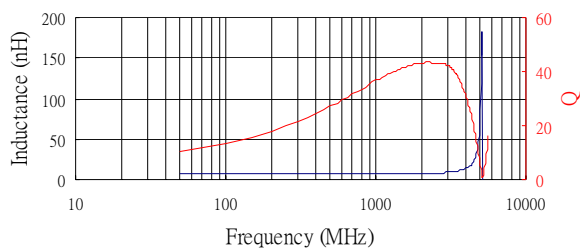

**AL03BT8N2**

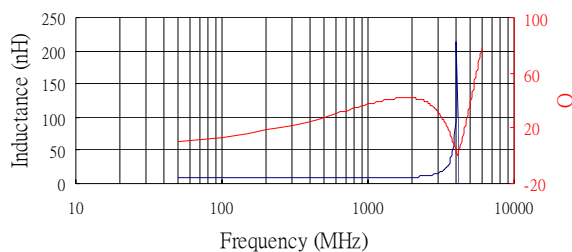

**AL03GT10N**

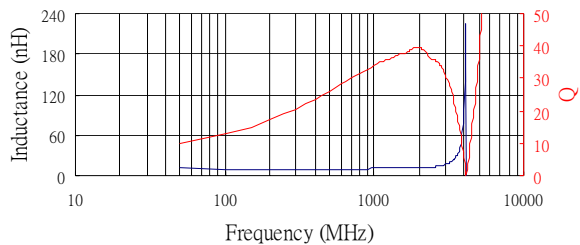

**AL03GT12N**

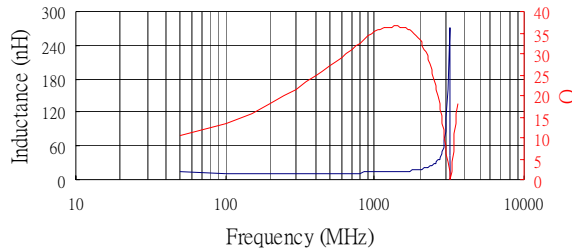

**AL03GT15N**

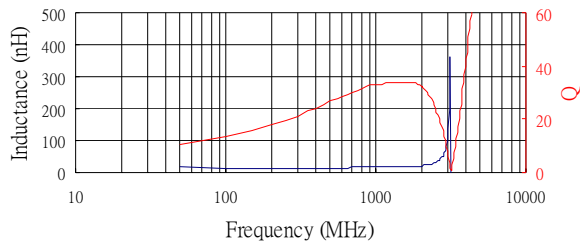

**AL03GT18N**

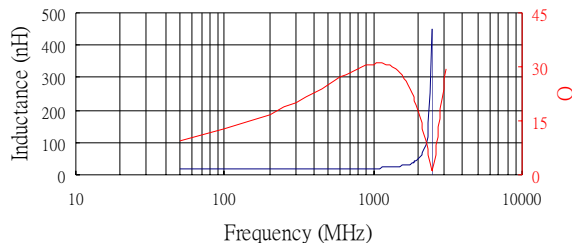

**Inductor Electrical Characteristics-0603 Series**

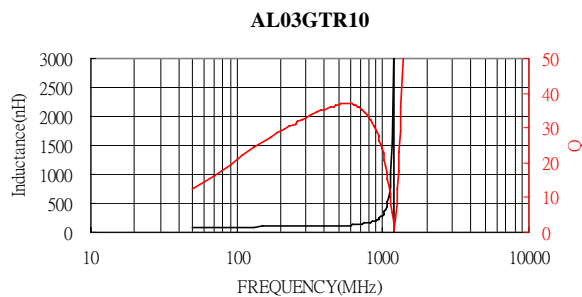
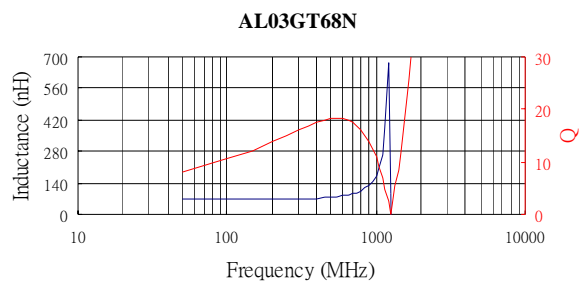
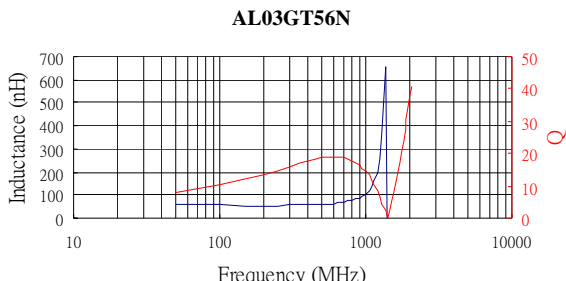
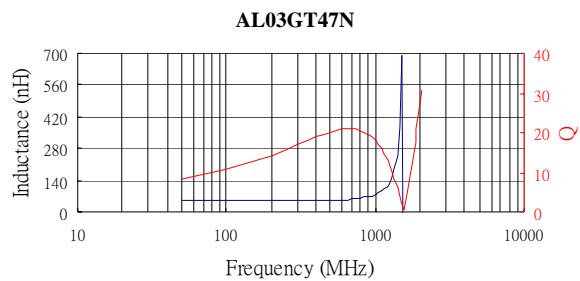
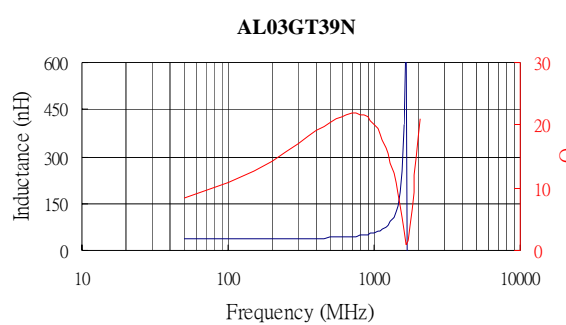
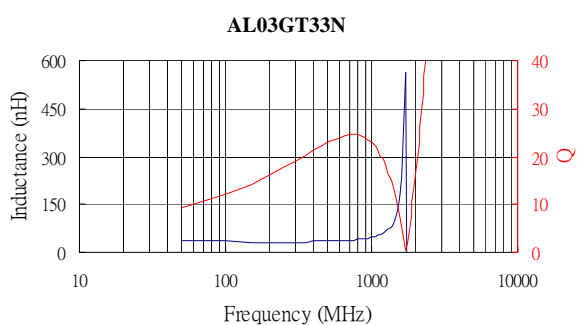
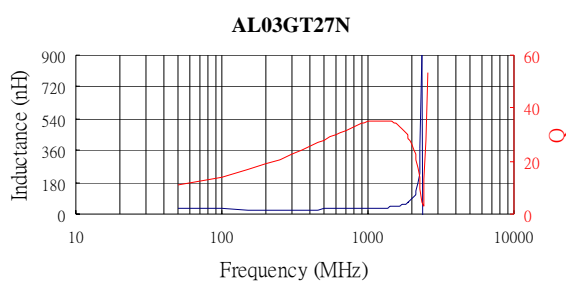
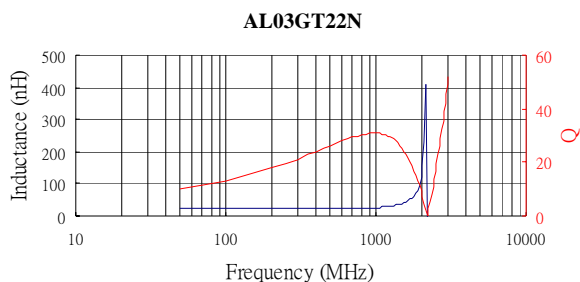

**Packaging**

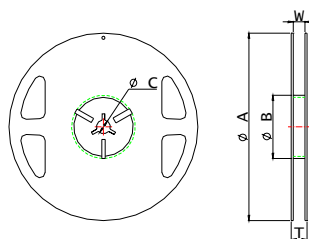

**Reel Specifications & Packaging Quantity**

Unit: mm

Codes	ΦA	ΦB	ΦC	W	T	Paper Tape (EA)
AL02	178±1	60.2±0.5	13.0±0.50	13.2±1.50	16.0±0.20	10,000
AL03	178±1	60.0±0.5	13.0±0.20	9.00±0.5	12.0±0.15	5,000

**Paper Tape Specifications**

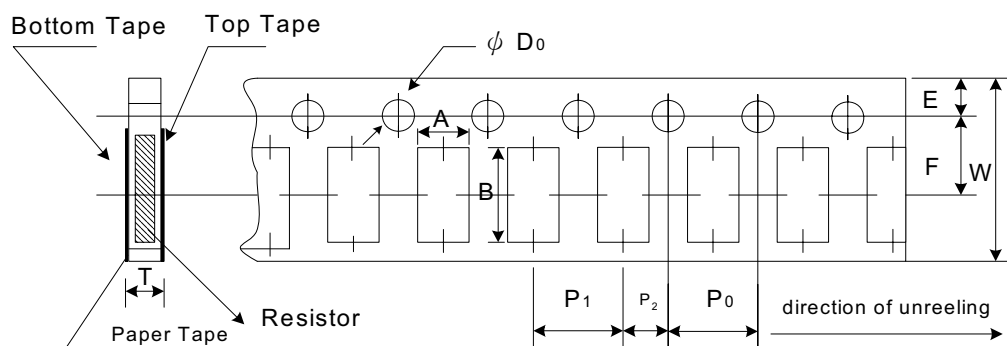

Unit: mm

Codes	A	B	W	E	F	P <sub>0</sub>	P <sub>1</sub>	P <sub>2</sub>	ΦD <sub>0</sub>	T
AL02	0.70±0.05	1.16±0.05	8.00±0.10	1.75±0.05	3.5±0.05	4.00±0.10	2.00±0.05	2.00±0.05	1.55±0.05	0.40±0.03
AL03	1.10±0.05	1.90±0.05	8.00±0.10	1.75±0.05	3.5±0.05	4.00±0.10	4.00±0.10	2.00±0.05	1.55±0.05	0.60±0.03

**Environmental Characteristics**

Item	Specification	Test Method
1 Bending Test	As SPEC.	JIS-C-5202-6.1.4 Bending Amplitude 3mm for 10 seconds
2 Dielectric Withstand Voltage	>100V	MIL-STD-202F Method 301. Apply 100VA (rms) for 1minute.
3 Insulation Resistance	>1000MΩ	MIL-STD-202F Method 302 Apply 100VDC for 1minute.
4 Resistance to Soldering Heat	ΔL ≤ 10%	MIL-STD-202F Method 210E 260±5°C, 10±1seconds
5 High Temperature Exposure	ΔL ≤ 10%	JIS-C-5202-7.2 85±2°C, 1000 +48/-0 hours
6 Moisture Resistance	ΔL ≤ 10%	MIL-STD-202F Method 103B 40±2°C, 90~95%RH, 1000 +48/-0 hours
7 Low Temperature Storage	ΔL ≤ 10%	JIS-C-5202-7.1 -40±3°C, 1000 +48/-0 hours
8 Temperature Cycle	ΔL ≤ 10%	JIS-C-5202-7.4 -40/RT/85/RT, 10 cycles
9 Solderability	95% min coverage	MIL-STD-202F Method 208H 235°C±5°C, 2±0.5(sec)

\* Storage Temperature :25±3°C; Humidity <80%RH