

SINLOON® 高壓貼片開關二極管
Chip Switching Diode

CD4148WN (1206)
100V 0.15A

FEATURE

- Silicon epitaxial planar diode
- Surface mount pattern , available in various dimension included 1206
- Lead free and RoHS compliance components.
- Fast AC switching input as rectified circuit and high reverse voltage location.

Figure



Cathode Band Color: white

MECHANICAL CHARACTERISTICS

- Size : 1206
- Weight: Approx 10mg.
- Marking: Cathode band.

Application

- Power supply
- Adapter
- Inverter



Electrical Symbol

DIMENSION

Dimension (mm)	Type: 0805
L	3.2 ± 0.2
W	1.50 ± 0.2
T	0.85 ± 0.1
C	0.55 ± 0.2

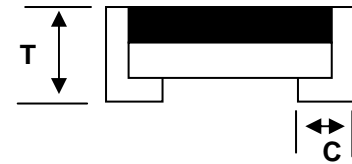
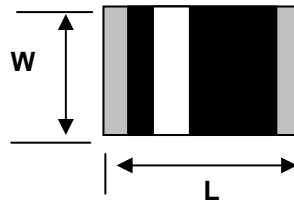

THERMAL CHARACTERISTICS

Parameter at Tamb = 25°C *1	Symbol	Value	Unit
Junction Temperature	T _j	150	°C
Thermal Resistance Junction to Ambient air	R _{θJA}	375	°C/W
Storage Temperature range	T _{stg}	-55 to 150	°C

*1. Valid provided that electrodes are kept at ambient temperature.

ELECTRICAL CHARACTERISTICS

Parameter at Tamb = 25°C	Symbol	Value	Unit
Repetitive Peak Reverse Voltage	V _{RRM} (VPK)	100	V
Forward Continuous Current _{amb=25°C}	I _{FRM}	300	mA
Average rectified current sin half wave rectification with resistive load	I _{F(AV)}	150	mA
Non-Repetitive Surge Forward Current at t<1s and T _j =25°C; at t≤8.3ms and T _j =25°C.	I _{FSM}	500 1000	mA
Forward Power Dissipation Power derating above 25°C.	P _{tot}	400 3.2	mW mW/°C
Forward Voltage at I _F =10mA	V _F	1.0 max	V
Forward Voltage at I _F =100mA		1.25 max	
Leakage Current at V _R =20V	I _R	25 max	nA
Leakage Current at V _R =75V		0.5 max	µA
Capacitance at V _R =0V, f=1MHz.	C _{tot}	4 max	pF
Voltage rise when switching ON, Testes with 50mA pulses, T _P =0.1us, risetime <20ns, F _p =(5-	V _{fr}	2.5 max	V
Reverse Recovery Time at I _F =100mA to I _R =1mA, V _R =V ₆ , R _L =100Ω	T _{RR}	4.0 max	ns
Rectification efficiency at f=100MHz, V _{RF} =2V	nr	45 min	%

1. Valid provided that electrodes are kept at ambient temperature.

MAYLOON ELECTRONIC CO., LTD.,



SINLOON® 高壓貼片開關二極管
Chip Switching Diode

CD4148WN (1206)
100V 0.15A

TEST CHARACTERISTICS:

Test Item	Test Condition	Requirement
Solder ability	Sn bath at 245±5°C for 2±0.5s	>95% area tin covered
Resistance to Soldering Heat	Sn bath at 260±5°C for 10±0.5s	V _F , V _Z , & I _R Within spec, no mechanical damage
Humidity Steady State	At 85°C 85%RH for 168hrs	V _F , V _Z , & I _R Within spec
Continue Forward Operating Life	At 25°C I _F = 1.1 I _F for 1000hrs	V _F , V _Z , & I _R Within spec
Hi-Temperature Reverse Bias	At 150°C V _R = 0.8V _R rated for 1000hrs	V _F , V _Z , & I _R Within spec
Thermal Shock	-55±5°C/5min to 150±5°C/5min for 10cycles	V _F , V _Z , & I _R Within spec
Bending Strength	Bending up to 2mm for 1 cycle	V _F , V _Z , & I _R Within spec, no mechanical damage

APPLICATIONS:

- Function: Fast Switching.
- Soldering Condition:

Soldering Condition & Caution:

- Recommended Soldering Condition (Refer to IPC/JEDEC J-STD-020D 5-1)

Recommended Profile Condition	Sn-Pb Soldering	Lead-free Soldering	Wave Soldering
Ramp-up rate (from pre-heat stage)	<3°C/s	<3°C/s	ΔT<150°C
Pre-heat Temperature & Time	100-150°C, 60~120s	100-200°C, 60~120s	100-150°C, 60~120s
Soldering Temperature & Time	183°C, 60~150s	270°C, 60~150s	260±5°C, 5±2s
Peak Temperature	230±5°C, <260°C	245±5°C, <260°C	260±5°C
Time within 5°C of peak temperature	10~20s	20~30s	-
Ramp-down rate	<6°C/s	<6°C/s	<6°C/s
Time 25°C to peak temperature	<6min	<8min	-

Manual Soldering: Approx. 350°C for 3s, avoid solder iron tip direct touch the components body.

RECTIFICATION EFFICIENCY MEASUREMENT CIRCUIT

※Fast AC switching input as rectified circuit and high reverse voltage location.

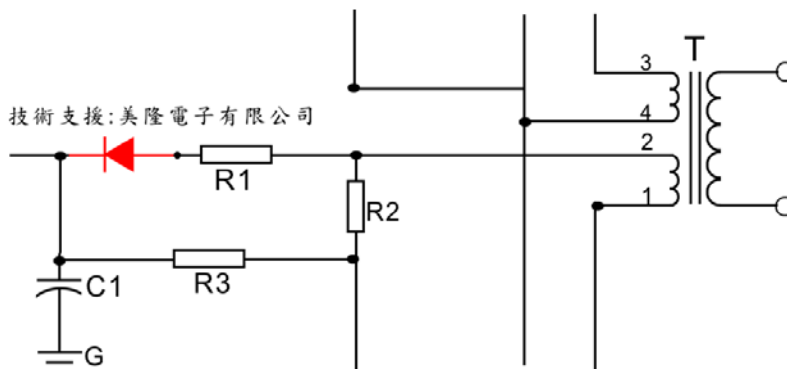

DEVICE OUTLOOK:

Plant front side



Plant back side

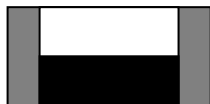

PRODUCT STRUCTURE

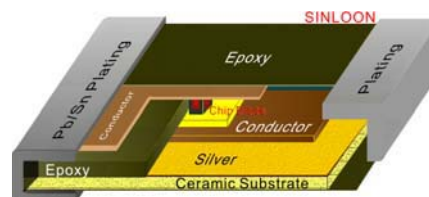

SINLOON® 高壓貼片開關二極管
Chip Switching Diode

CD4148WN (1206)
100V 0.15A

□ TYPICAL CHARACTERISTICS

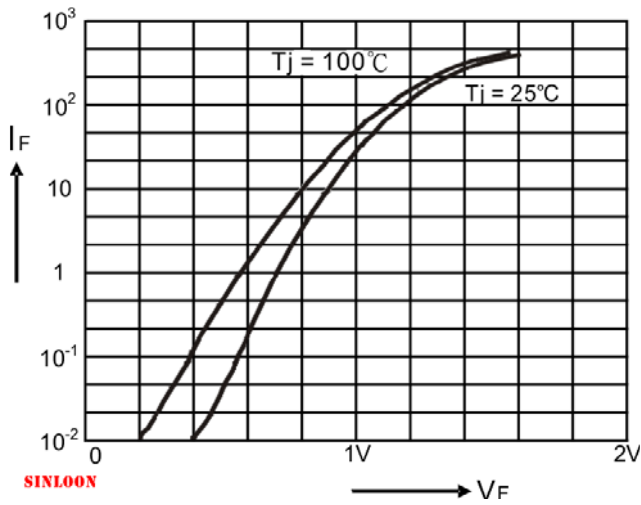

Figure 1 : Forward Characteristics

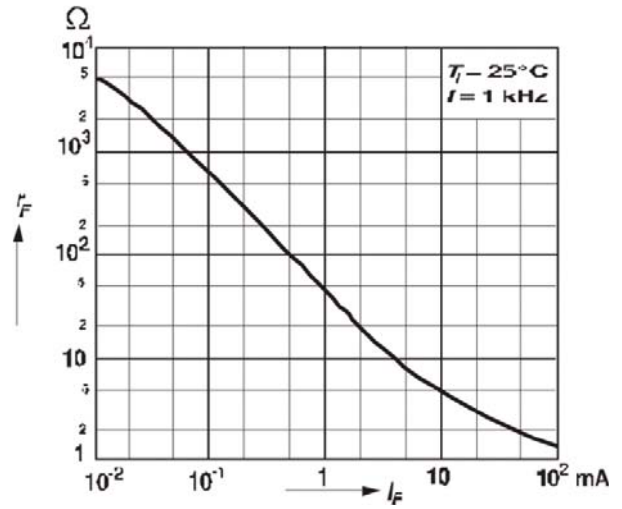

Figure 2 : Dynamic Forward Resistor VS Forward Current

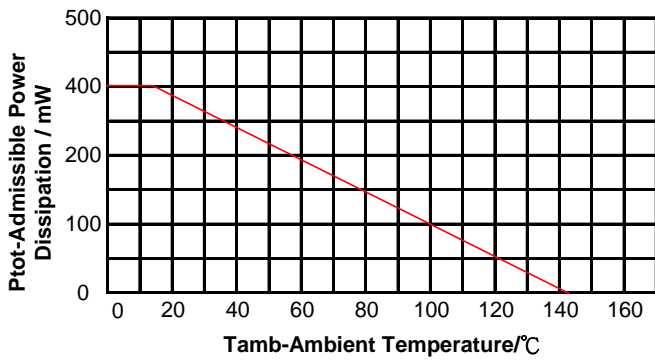

Figure 3 : Power De-rating

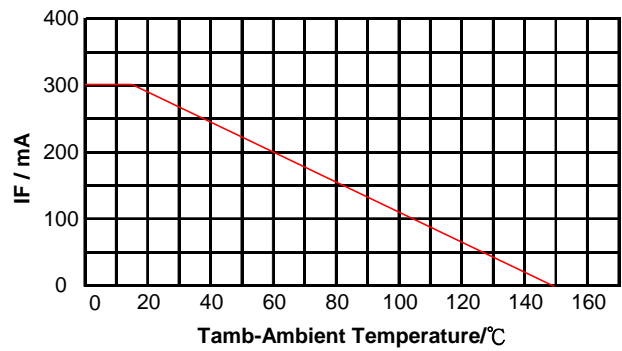

Figure 4 : Forward Current De-rating

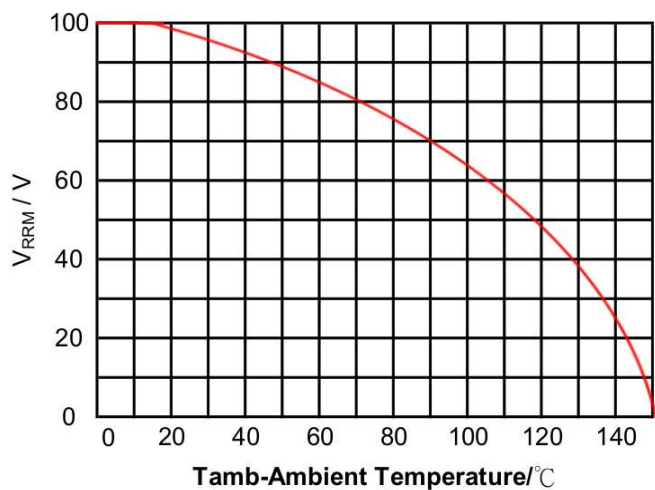

Figure 5 : Reverse Voltage De-rating



**SINLOON® 高壓貼片開關二極管
Chip Switching Diode**

**CD4148WN (1206)
100V 0.15A**

RECOMMENDED SOLDERING PROFILE:

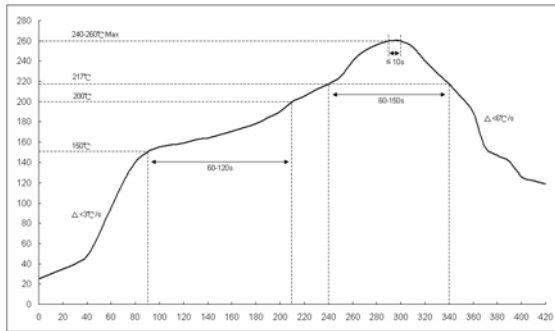

Fig 1: Reflow soldering profile for lead-free solder (SnAgCu)

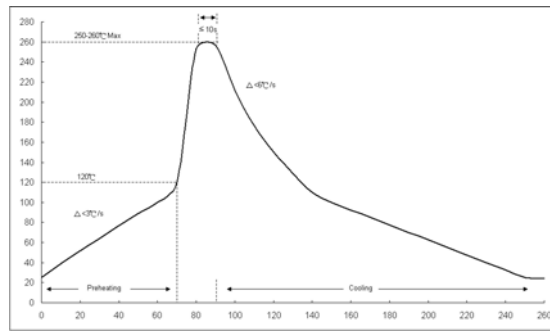

Fig 2: Wave soldering profile.

* The recommended profiles are referring to IPC/JEDEC J-STD-020D & IEC-60068-2-58

* Chip diode are to stabd maximum soldering temperture up to 260°C max. for 10s, and the soldering cycles with max. 3 times, referring to IEC-60068-2-58

RECOMMENDED SOLDERING FOOTPRINT

Reflow/Wave Soldering:

Size:	Dimension (mm)			
	A	B	C	D
0603	1.8~2.6	0.8	0.5~0.9	0.8~1.0
0805	2.2~3.0	1.2	0.5~0.9	1.2~1.4
1206	3.4~4.2	2.1~2.2	0.6~1.0	1.5~1.7

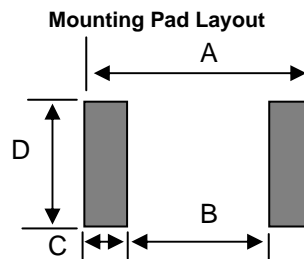

■ Storage Condition: Product termination solderability can degrade due high temperature and humidity or chemical environment, Storage condition must be in an ambient temperature of <40°C and ambient humidity of <75%RH, and free from chemical.

ENVIRONMENTAL CHARACTERISTICS

Product	Hazerdous Substance or Element / ppm					
	Pd	Cd	Hg	Cr ⁶⁺	PBB	PBDE
CD4148WTP	<1000	<100	<1000	<1000	<1000	<1000
CD4148WSN	<1000	<100	<1000	<1000	<1000	<1000
CD4148WN	<1000	<100	<1000	<1000	<1000	<1000
Product	Halogen Substance / ppm					
	F	Cl	Br	I	-	Total
	<900	<900	<900	<900	-	<1500

PACKING METHOD:

Product	Quantity / Reel	Reel Size	Tape	Approx Gross Weigh
CD4148WTP	5000	7"	Paper	10.5 Kgs/300K Ctn
CD4148WSN	5000	7"	Paper	10.5 Kgs/300K Ctn
CD4148WN	5000	7"	Paper	13.0 Kgs/300K Ctn

Carton:

Size: 39x39x20 cm
Quantity: 300K / Ctn.
In Box: 6 Box
Box Qty: 50K/Box
Type Reel: 5K/Reel

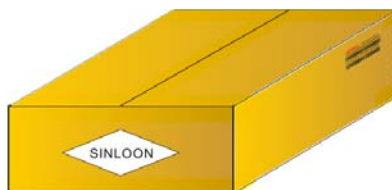

SINLOON® 高壓貼片開關二極管
Chip Switching Diode

CD4148WN (1206)
100V 0.15A

□ PACKAGE

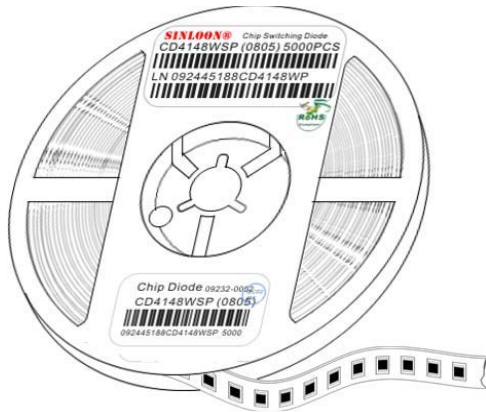

Plastic reel front side

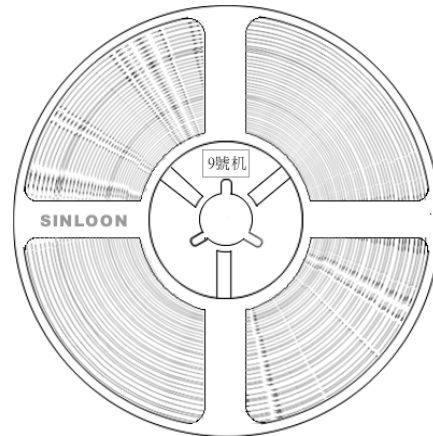

Plastic reel back side

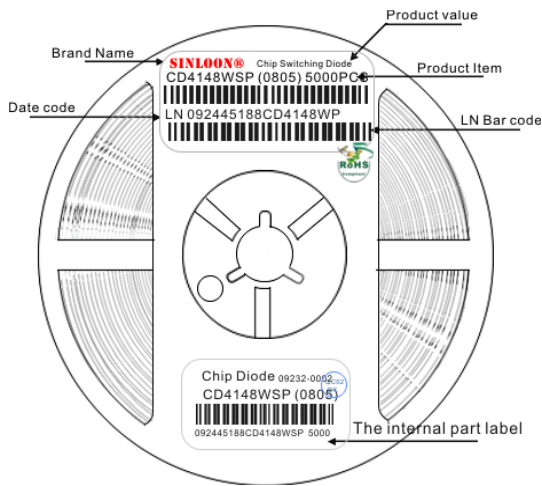

Reel label

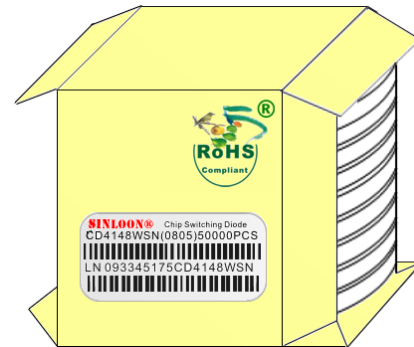

In box packing

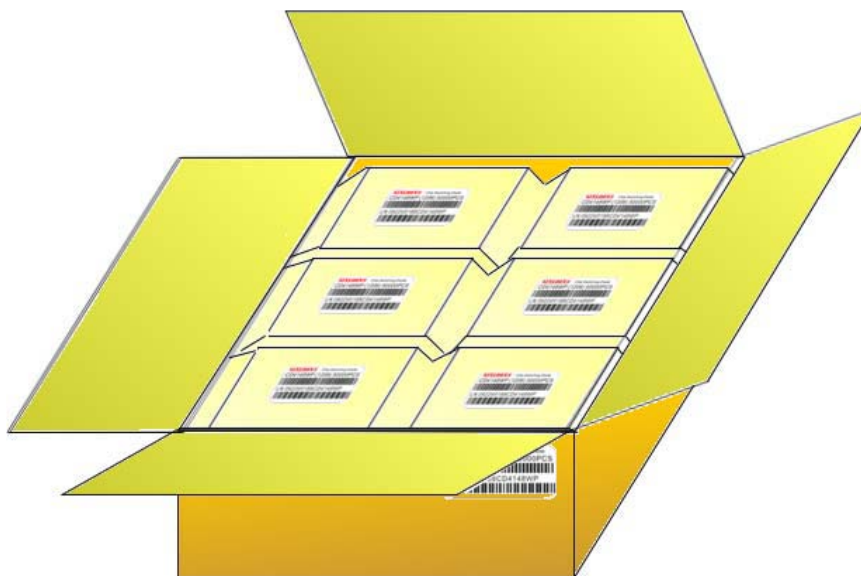

Carton Packing

※美隆電子產品規格特性參數的改變或更新,將不會另行通知。

※Mayloon characteristic parameters of electronic product specification changes or updates without prior notice。