

SINLOON®

突波吸收器(壓敏電阻)  
DC 18V ~ 112V

10D Series  
Zine Oxide Varistor

□ FEATURE

- A wide protecting voltage range.(18V-1800V)
- Low leakage current in Preparatory State.( $<20\mu\text{A}$ )
- Fast response to transient voltage.( $<50\text{ns}$ )
- Low clamping ratio.
- High withstanding surge current.
- High energy capability.
- No following-on current.

□ APPLICATIONS

- Tansistor, Diode, IC, Thyristor and semiconductor protection.
- Protection in Consumer, Industrial electronics.
- Protection in communication, measuring and controller electronics.
- Protection in electronic home appliances.
- Electrostatic discharge and noise suppression.
- Relay and electromagnetic valve surge absorption.

□ ORDERING INFORMATION

Example: SVR-20D331KCB (20mm 330V  $\pm 10\%$  10mm Bulk)

Code	Dimension		Disc Type	Voltage	Tolerance	Lead style (Pitch)		d $\Phi$ (mm)	Pack
SVR	05	$\Phi$ 5.0mm	D	180~561V	K = $\pm 10\%$	A	5.0 $\pm$ 1.0mm	$\Phi$ 0.6	B = Bulk
	07	$\Phi$ 7.0mm		180~681V					
	10	$\Phi$ 10mm		180~112V					
	14	$\Phi$ 14mm		180~182V					
	20	$\Phi$ 20mm		180~182V					

FIGURE



Fig-1

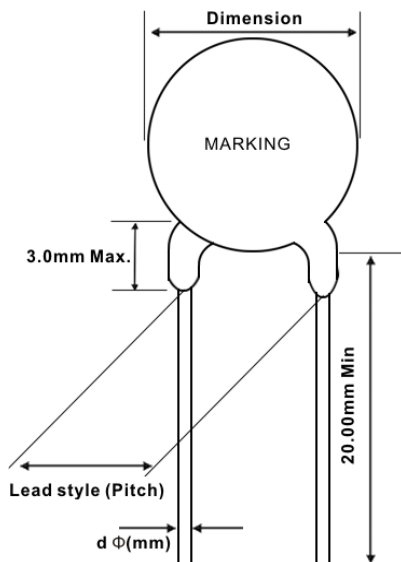

Fig-2

□ 電氣特性

- 可分辨穩定電路電壓或突波電壓，但只在突波電壓發生時才進行運作。
- 吸收突波後，即恢復吸收突波前的預備狀態（可反覆使用）。
- 吸收突波電壓時的抑制電壓，比被保護機器的耐電壓、誤動作電壓還低。
- 可耐得住反覆所施加的突波電壓。



**SINLOON®**

突波吸收器(壓敏電阻)  
DC 18V ~ 112V

10D Series  
Zinc Oxide Varistor

□ MATERIALS AND MARKING

Marking:	Value Marking	Fig-3
Electrode Material:	Ag Paste	
Coating Material:	Epoxy	
Lead Material:	Tin Plated Copper Wir	

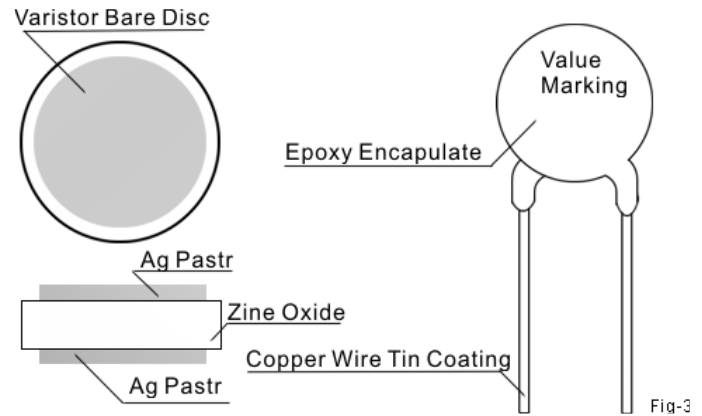

□ DIMENSION

Unit: mm

Series	05D	07D	10D	14D	20D	Figure
D (Max)	7.5	9.0	14.0	17.0	25.0	Fig-4
d (±0.02)	0.6	0.6	0.8	0.8	1.0	
F (±1.0)	5.0	5.0	7.5	7.5	10.0	
H (Max)	10.5	12.0	17.0	20.0	28.0	

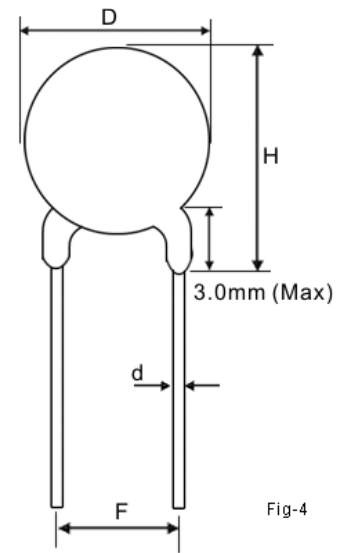

□ DIMENSION T-max Table

Part No.	05D	07D	10D	14D	20D	Figure
180K	4.5	4.5	4.6	4.6	5.3	Fig-5
220K	4.5	4.6	4.7	4.7	5.4	
270K	4.5	4.7	4.8	4.8	5.5	
330K	4.5	4.9	5.0	5.0	5.6	
390K	4.5	4.8	4.9	4.9	5.5	
470K	4.5	4.9	5.0	5.0	5.6	
560K	4.5	5.0	5.1	5.1	5.7	
680K	4.5	5.2	5.3	5.3	5.8	
820K	4.1	4.1	4.5	4.5	4.9	
101K	4.3	4.3	4.7	4.7	5.1	
121K	4.5	4.5	4.9	4.9	5.3	
151K	4.8	4.8	5.2	5.2	5.6	
181K	4.3	4.3	4.8	4.8	5.2	
201K	3.4	4.4	4.8	4.8	5.2	
221K	4.5	4.5	4.9	5.0	5.3	
241K	4.6	4.6	5.0	4.9	5.4	
271K	4.9	4.9	5.2	5.2	5.6	
301K	5.0	5.0	5.3	5.3	5.7	
331K	5.1	5.1	5.6	5.6	6.0	
361K	5.2	5.2	5.7	5.7	6.2	
391K	5.4	5.4	5.8	5.8	6.4	
431K	5.7	5.7	6.2	6.2	6.7	
471K	6.0	6.0	6.5	6.5	7.0	
511K	6.2	6.4	6.5	6.5	7.0	
561K	6.2	6.4	6.5	6.5	7.0	
621K	●	7.1	7.1	7.1	7.5	
681K	●	7.3	7.4	7.4	7.8	
751K	●	●	7.8	7.8	8.2	
781K	●	●	7.9	7.9	8.3	
821K	●	●	8.1	8.1	8.5	
911K	●	●	8.6	8.6	9.0	
102K	●	●	9.1	9.1	9.5	
112K	●	●	9.7	9.7	10.1	
182K	●	●	●	14.1	14.8	

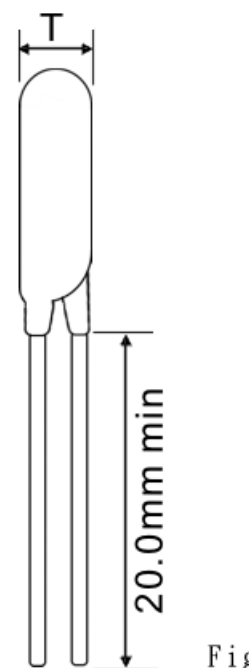

Fig



MAYLOON ELECTRONIC CO., LTD.,

□ DEFINITION OF TECHNICAL TERMS

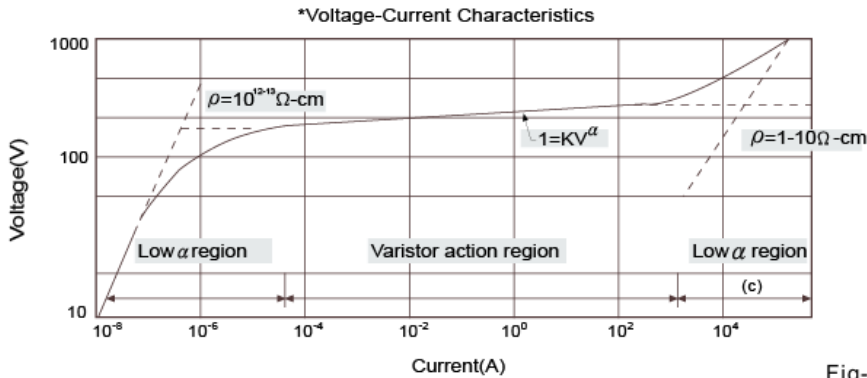

Fig-6

- Varistor Voltage(breakdown voltage):  
The varistor voltage is the voltage across the varistor measured at a specified current  $I_c$  (0.1mA or 1mA) of specified duration.
- Max. allowable Voltage and leakage current  
The maximum operating voltage corresponds to the "rest" state of the varistor. This "rest" voltage offers a low leakage current in order to limit the power consumption of the protective device and not to disturb the circuit to be protected. The leakage currents usually have values in the range of a few micro-amperes.
- Non linear exponent  $\alpha$  ):  
The varistor voltage-current characteristic is defined by the equation:  
 $I=KV^\alpha$ , where K is a constant dependent on geometry, and  $\alpha$  is the non linear exponent.  
We usually take two points  $(V_1, I_1), (V_2, I_2)$  to estimate the value of  $\alpha$ . In which  $I_1$  and  $I_2$  are the current value corresponding to the voltage value  $V_1$  and  $V_2$
- Rated power:  
The maximum power that can be applied within the specified ambient temperature.
- Capacitance:  
The capacitance of varistor is the reference value measured between the varistor terminals at specified frequency.
- Withstanding surge current:  
Withstanding surge current is the maximum peak current for the varistor with the specified standard impulse current (8x20 sec) applied one time or two times and corresponding to a permissible variation of 10% in the varistor voltage change.
- Maximum clamping voltage:  
Maximum clamping voltage is the maximum voltage  $V_p$  between two terminals with the specified standard impulse current  $I$  (8x20 sec). The voltage value is an indication on the protective function of the varistor.
- Energy  
Maximum energy from one or a burst of pulses. It is the value within the varistor change of 10% when one impulse of 10x1000 sec is applied.  
 $E=KxVmxImxT$   
E:Energy  
K:constant=1.4  
 $V_m$ : Max. clamping voltage at  $I_m$ .  
 $I_m$ : Max. allowable single surge current of 10x1000 sec.  
T: Duration of surge current(1000 sec)
- Pulse life time rating  
This is expressed as the maximum allowable number of impulse currents applied. 8x20 sec impulse current (or 10x1000 sec) is applied at prescribed interval.  
This curve also provides for derating current as required repetitive pulsing.  
 $t_1=8 t_2=20$  for 8 20 sec  
 $t_1=10 t_2=1000$  for 10 1000 sec

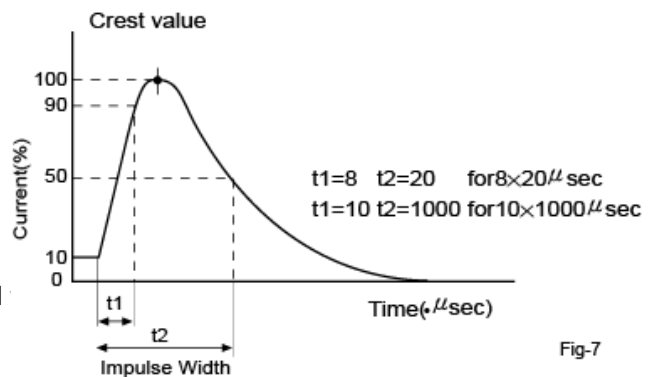

Fig-7



SINLOON®

突波吸收器(壓敏電阻)  
DC180K ~ 112K (V)

10D Series  
Zinc Oxide Varistor

☐ 10D Series

Part Number	Maximum Allowable Voltage		Varistor Voltage V <sub>0.1mA</sub>	Clamping Voltage (Max.)		Maximum Peak Current (8/20μs)(A)		Maximum Energy (JOULE)		Rated Power w	Typical Capacitance (Reference) @1 KHz(pF)
	ACrms(V)	DC(V)		VC(V)	I <sub>p</sub> (A)	1 Time	2 Time	10/1000 μs	2ms		
SVR-10D180K	11	14	18(15.5-21)	36	5	1000	500	2.2	2.2	0.05	8000
SVR-10D220K	14	18	22(20-24)	43	5	1000	500	2.6	2.6	0.05	7000
SVR-10D270K	17	22	27(24-30)	53	5	1000	500	3.2	3.2	0.05	6000
SVR-10D330K	20	26	33(30-36)	65	5	1000	500	4.0	4.0	0.05	5000
SVR-10D390K	25	31	39(35-43)	77	5	1000	500	4.7	4.7	0.05	4500
SVR-10D470K	30	38	47(42-52)	93	5	1000	500	5.6	5.6	0.05	4000
SVR-10D560K	35	45	56(50-62)	110	5	1000	500	7.0	6.7	0.05	3500
SVR-10D680K	40	56	68(61-75)	135	5	1000	500	8.2	8.2	0.05	3200
SVR-10D820K	50	65	82(74-90)	135	25	3500	2500	12.0	10.0	0.4	1700
SVR-10D101K	60	85	100(90-110)	165	25	3500	2500	15.0	12.0	0.4	1600
SVR-10D121K	75	100	120(108-132)	200	25	3500	2500	18.0	14.5	0.4	1400
SVR-10D151K	95	125	150(135-165)	250	25	3500	2500	22.0	18.0	0.4	1300
SVR-10D181K	115	150	180(162-198)	300	25	3500	2500	27.0	18.5	0.4	690
SVR-10D201K	130	170	200(185-225)	340	25	3500	2500	30.0	25.0	0.4	500
SVR-10D221K	140	180	220(198-242)	360	25	3500	2500	32.0	27.5	0.4	450
SVR-10D241K	150	200	240(216-264)	395	25	3500	2500	35.0	30.0	0.4	400
SVR-10D271K	175	225	270(243-297)	455	25	3500	2500	40.0	35.0	0.4	350
SVR-10D301K	190	250	300(270-330)	500	25	3500	2500	40.0	32.0	0.4	325
SVR-10D331K	210	275	330(297-363)	550	25	3500	2500	43.0	42.0	0.4	300
SVR-10D361K	230	300	360(324-396)	595	25	3500	2500	47.0	45.0	0.4	280
SVR-10D391K	250	320	390(351-429)	650	25	3500	2500	60.0	50.0	0.4	260
SVR-10D431K	275	350	430(387-473)	710	25	3500	2500	65.0	55.0	0.4	240
SVR-10D471K	300	385	470(423-517)	775	25	3500	2500	70.0	60.0	0.4	220
SVR-10D511K	320	415	510(459-561)	845	25	3500	2500	70.0	67.0	0.4	210
SVR-10D561K	350	460	560(504-616)	925	25	3500	2500	70.0	67.0	0.4	195
SVR-10D621K	385	505	620(558-682)	1025	25	3500	2500	70.0	67.0	0.4	180
SVR-10D681K	420	560	680(612-748)	1120	25	3500	2500	70.0	67.0	0.4	165
SVR-10D751K	460	615	750(675-825)	1240	25	3500	2500	75.0	70.0	0.4	150
SVR-10D781K	485	640	780(702-858)	1290	25	3500	2500	80.0	50.0	0.4	140
SVR-10D821K	510	670	820(738-902)	1355	25	3500	2500	85.0	80.0	0.4	140
SVR-10D911K	550	745	910(819-1001)	1500	25	3500	2500	93.0	90.0	0.4	125
SVR-10D102K	625	825	1000(900-1100)	1650	25	3500	2500	102.0	100.0	0.4	115
SVR-10D112K	680	895	1100(990-1210)	1815	25	3500	2500	115.0	110.0	0.4	105

MAYLOON ELECTRONIC CO., LTD.,





□ 10D Series

V - I Curve

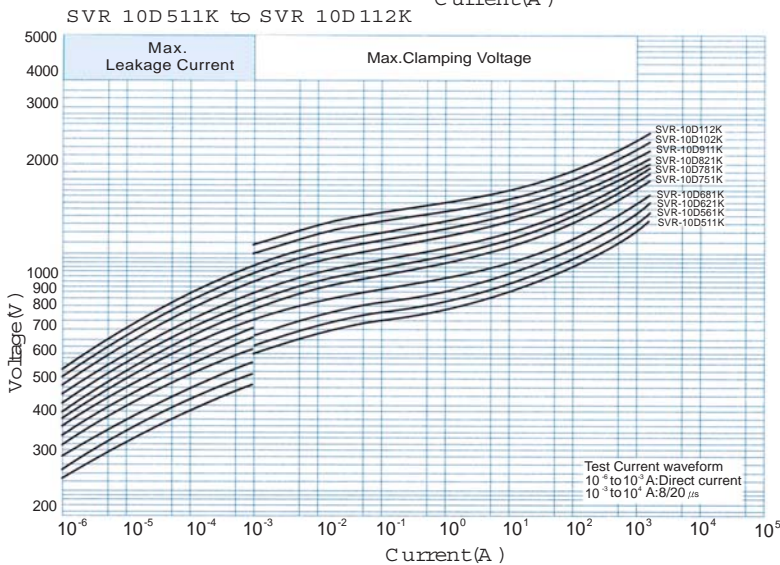
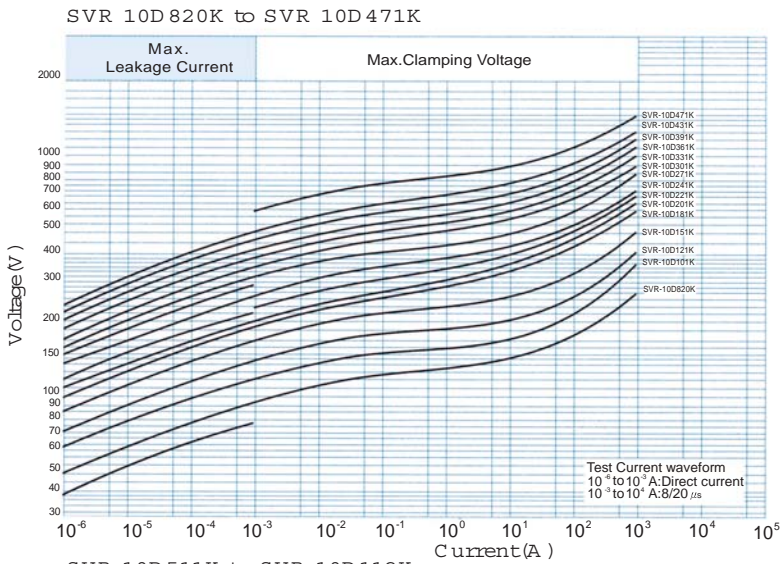
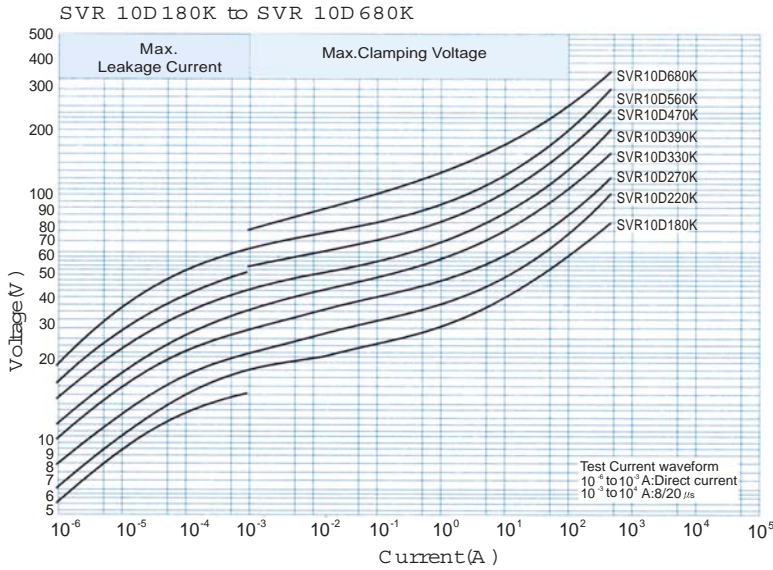

Im Pulse Life Time Ratings

